



National Fenestration Rating Council Incorporated

NFRC 100-2004

Procedure for
Determining Fenestration Product U-Factors

© 2004 NATIONAL FENESTRATION RATING COUNCIL, INC.

PREPARED BY:

National Fenestration Rating Council
8484 Georgia Avenue, Suite 320
Silver Spring, MD 20910
Voice: (301) 589-1776
Fax: (301) 589-3884
Email: info@nfr.org
Website: www.nfr.org



FOREWORD

Consumers today have many energy saving fenestration product options to choose from. Advances in fenestration product technologies include the use of low-Emissivity coatings, low-conductivity gas-fills, insulating spacers and new frame materials and designs. While the use of one or more of these components will improve fenestration product thermal performance, it will also increase the complexity of the selection process.

This procedure has been developed by the National Fenestration Rating Council (NFRC) to meet the need for a uniform and accurate means for evaluating the U-Factors of fenestration systems. This procedure uses state-of-the-art computer simulation software tools, with periodically updated optical properties and physical hot-box testing. The U-Factors established by this procedure are determined at a fixed set of environmental conditions. Consequently, the U-Factors determined using this procedure may not be appropriate for directly determining seasonal energy performance.

This document combines and replaces NFRC 100-2001. The companion procedure to evaluate total product solar heat gain coefficient and visible transmittance is NFRC 200; to determine glazing layer optical properties is NFRC 300; to determine air leakage rates is NFRC 400; and to determine condensation resistance rating is NFRC 500.

Ratings per this procedure are based on computer simulations. A physical test on a representative specimen is used to validate product conformance and the computer simulations. Products that cannot be simulated use ratings based on physical testing.

This document is in SI units followed by IP units in parentheses. SI units are primary. IP units are conversions for reference only.

Questions on the use of this procedure should be addressed to:

<p>National Fenestration Rating Council 8484 Georgia Avenue, Suite 320 Silver Spring, MD 20910 Voice: (301) 589-1776 Fax: (301) 589-3884 Email: info@nfrc.org Website: www.nfrc.org</p>
--



Table of Contents

Foreword		ii
1. Purpose		1
2. Scope		1
2.1 PRODUCTS COVERED		1
2.2 PRODUCTS AND EFFECTS NOT COVERED		1
3. Definitions		2
4. General		9
4.1 COMPLIANCE		9
4.1.1 Product Line Simulation and Testing		9
Table 4-1: Representative Size Matrix of U-Factors		10
4.1.2 Testing Alternative.....		10
4.1.3 Custom Product Rating.....		11
4.1.4 Dynamic Glazing Product Rating.....		11
4.2 PRODUCT LINES AND INDIVIDUAL PRODUCTS.....		11
4.2.1 Product Lines		12
4.2.2 Individual Products		13
4.2.3 Validation Test Matrix		14
4.2.3.1 Same Product Type		14
4.2.3.2 Multi-purpose products.....		14
4.2.4 Grouping of Products.....		15
4.2.4.1 Center-of-Glazing Grouping.....		15
4.2.4.2 Grouping of Shading Systems between Glazing Layers.....		16
4.2.4.3 Spacer Grouping		16
4.2.4.4 Divider Grouping		16
4.2.4.5 Frame Grouping.....		17
4.2.5 General Simulation Rules		17
4.2.6 General testing rules		18
4.2.7 General rating rules.....		19
4.2.8 Additions to the Product Line		19
4.3 STANDARD CONDITIONS		19
4.3.4 Simulation.....		19
Table 4-2: Boundary Conditions.....		21

4.3.5	Testing.....	21
4.3.5.1	Total Fenestration Product Test Procedure.....	21
4.3.5.2	Center-of-Glazing Component Test Procedure	22
4.3.5.3	Component Substitution.....	22
4.4	MODEL SIZES AND CONFIGURATIONS	22
	Table 4-3: Product Types and Model Sizes	23
4.5	SIMULATION PROCEDURES.....	24
4.5.1	Total Fenestration Product U-Factors for Model Sizes	24
4.5.2	Total Fenestration Product.....	24
4.5.3	Component.....	25
4.5.3.1	Approved Center-of-Glazing Simulation Programs	25
4.5.3.2	Approved 2-D Heat Transfer Simulation Programs	25
4.6	TEST PROCEDURES.....	25
4.6.1	Total Fenestration Product.....	25
4.6.2	Component.....	26
4.6.2.1	Glazing Component Test Procedure	26
4.6.3	Calculation Procedure.....	26
4.6.4	Reporting of Ratings	27
4.7	VALIDATION	28
4.7.1	Equivalence.....	28
	Table 4-4 Equivalence	28
4.8	FIGURES.....	29
	Figure 4-1 Fenestration Product Schematic-Vertical Elevation	29
	Figure 4-2 Fenestration Product Schematic-Vertical Section.....	30
	Figure 4-3 Divider Height and Divider Width.....	31
	Figure 4-4 Sightline Examples.....	32
	Figure 4-5 Integral Ventilators.....	33
5	Variations from the General Requirements.....	34
5.1	WINDOWS AND SLIDING GLASS DOORS	34
5.1.1	Scope	34
5.1.2	Variations from Standard Product Lines.....	34
5.1.3	Variations from Standard Individual Products	34
5.1.4	Variations from Standard Simulation and Test Conditions	34
5.1.5	Calculation of Total Product Rating.....	34
5.1.6	Figures.....	35
5.2	SWINGING DOORS	35
5.2.1	Scope	35
5.2.2	Variations from Standard Product Lines.....	35
5.2.3	Variations from Standard Individual Products	36
5.2.4	Variations from Standard Simulation and Test Conditions	36
5.2.5	Calculation of Total Product Rating.....	37
5.2.5.1	Simplifications	38
	Table 5-1 Glazing and Divider Patterns for Doors	39
	Table 5-2 Glazing and Divider Patterns for Sidelites	40
5.2.6	Figures.....	41

	Figure 5-1	Exterior Steel Composite Door System Area Schematic - Vertical Elevation	41
	Figure 5-2a	Exterior Steel/Composite Door System-Vertical Elevation in Steel Frame	42
	Figure 5-2b	Exterior Steel/Composite Door System-Vertical Elevation in Wood Frame	43
	Figure 5-3	Exterior Wood Door System -Vertical Elevation	44
	Figure 5-4	Typical 6-panel layout.....	45
	Figure 5-5	Common Pressed-Steel Frame - Single Unit Type Pressed-Steel Frame.....	46
	Figure 5-6	Frame Cross Section	47
	Figure 5-7	Wood Default	48
	Figure 5-8	Default Wood Door Head Jamb and Side Jamb.....	48
	Figure 5-9	Default Door Sill	49
5.3	SKYLIGHTS		49
	5.3.1	Scope	49
	5.3.2	Variations from Standard Product Lines.....	50
	5.3.3	Variations from Standard Individual Products	50
	5.3.4	Variations from Standard Simulation and Test Conditions	50
		5.3.4.1 Curb.....	50
		5.3.4.2 Size.....	50
		5.3.4.3 Skylight area	50
	5.3.5	Calculation of Total Product Rating	51
	5.3.6	Figures.....	52
5.4	TUBULAR DAYLIGHTING DEVICES		52
	5.4.1	Scope	52
	5.4.2	Variations from Standard Product Lines.....	53
	5.4.3	Variations from Standard Individual Products	53
	5.4.4	Variations from Standard Simulation and Test Conditions	53
		5.4.4.1 Orientation	53
		5.4.4.2 Sizes	53
		5.4.4.3 Tubular Daylighting Device area.....	53
		5.4.4.4 Standard Modeling Conditions	53
		5.4.4.5 Calculation of Total Product Rating	54
	5.4.5	Figures.....	55
	Figure 5-10	Tubular Daylighting Device Product Schematic: Vertical Elevation	55
5.5	GARAGE (VEHICULAR ACCESS) DOORS		55
	5.5.1	Scope	55
	5.5.2	Variations from Standard Product Lines.....	56
	5.5.3	Variations from Standard Individual Products	56
	5.5.4	Variations from Standard Simulation and Test Conditions	56
	5.5.5	Total Product Rating.....	57
	5.5.6	Figures.....	59
	Figure 5-11	Garage Door 2: Vertical Elevation, Glazing Area	59
	Figure 5-12	Garage Door Product Schematic-Vertical Elevation ...	60

	Figure 5-13 Garage Door Horizontal Jamb Schematic (Exterior)...	61
5.6	NON-RESIDENTIAL PRODUCTS.....	62
5.6.1	Scope	62
	5.6.1.1 Products Covered.....	62
	5.6.1.2 Systems not covered	62
5.6.2	Variations from Standard Product Lines.....	62
5.6.3	Variations from Standard Individual Products	62
5.6.4	Variations from Standard Simulation and Test Conditions	62
	5.6.4.1 Unspecified Product Sample Validation Criteria.....	62
	5.6.4.2 Determining the thermal transmittance for solarium/sunroom systems.....	63
5.6.5	Calculation of Total Product Rating	64
5.6.6	Figures.....	64
6	References.....	64
APPENDIX A	(Non-mandatory Information).....	66
	Table 6-1 Example U-Factor Size Matrix.....	67
Index	68

1. PURPOSE

To specify a method for determining fenestration product U-Factor (thermal transmittance).

2. SCOPE

2.1 Products Covered

- A. Products of all types as defined in Table 4-3.
- B. Products of all frame materials including, but not limited to, aluminum, steel, thermally broken aluminum, wood, vinyl, reinforced vinyl, fiberglass and plastic, used singularly or in combination or products utilizing foam as a core material.
- C. Products of all glazing materials, tints and types, including, but not limited to, clear glass, tinted glass, stained glass, glass block, thin plastic films (internally suspended, internally applied or externally applied), rigid plastics and translucent fiberglass with or without any solar control, low-E or any other partially transparent coating and products with manufactured decorative opaque insulated lazing panels, designed for interchangeability with other glazing options.
- D. Products with any or no gap width between glazing layers.
- E. Products with any spacer or spacer systems between glazings, including, but not limited to, metallic, non-metallic or composite spacers.
- F. Products utilizing any and all glazing dividers, including, but not limited to, interior, exterior or between glazing grilles, muntin bars, true divided lites or simulated divided lites.
- G. Products with any gas-fill between glazing layers, including, but not limited to, air, argon, krypton or mixes of these gases; and
- H. Products utilizing shading systems between glazing layers, currently limited to those that are an integral, i.e., non-removable, part of the product.
- I. Dynamic Glazing Products.

2.2 Products and Effects Not Covered

- A. Products with shading systems other than those listed in Section 2.1.
- B. Thermal performance changes of a fenestration product over the course of time, i.e., long-term energy performance; and
- C. Issues related to water tightness, structural capacity and air leakage.

3. DEFINITIONS

Areas:

Center-of-glazing area (A_c): all glazing areas except those within 63.5 mm (2.5 in.) of any part of a primary sash and/or frame and/or divider; or any part of a primary door and/or frame and/or divider. See Figure 4-1, Figure 4-2, Figure 5-1, Figure 5-2, Figure 5-3, Figure 5-11 and Figure 5-12.

Divider area (A_d): the projected area in the plane(s) parallel to the fenestration product's glazing of all interior or exterior applied non-removable dividers, true dividers, simulated dividers or between glazing dividers. See Figure 4-1, Figure 4-2, and Figure 5-1.

Door core area (A_{dc}): the projected area of the door less the frame, edge-of-frame, lite glazing frame, edge-of-glazing, center-of-glazing, edge-of-divider, divider, edge-of-panel and panel areas. See Figure 4-3, Figure 5-1, Figure 5-2 and Figure 5-3.

Edge-of-divider area (A_{de}): all glazed vision areas within 63.5 mm (2.5 in.) of any part of a divider area. The edge-of-divider area shall exclude any edge-of-glazing area. See Figure 4-1, Figure 4-2, Figure 5-1, Figure 5-2, Figure 5-3, Figure 5-11 and Figure 5-12.

Edge-of-glazing area (A_{eg}): all glazed vision areas within 63.5 mm (2.5 in.) of any part of the frame and sash or of the door lite frame sight line, excluding any divider or edge of divider. See Figure 4-1, Figure 4-2, Figure 5-1, Figure 5-2, Figure 5-3, Figure 5-11 and Figure 5-12.

Edge-of-panel area (A_{ep}): the projected area extending from the point 25 mm (1 in.) of uniform thickness on the panel, to the point which includes 25 mm (1 in.) of door core material from the interface of any decorative bead or from the interface of the panel cutout and the door core. See Figure 4-3, Figure 5-1, Figure 5-2 and Figure 5-3.

End stile area (A_{es}): the projected area of the end stile in the plane(s) parallel to the garage door surface. See Figure 5-12.

Frame area (A_f): the projected area of frame and sash in the plane(s) parallel to the glazing surface, except for doors, which shall include the projected areas of the door jambs, header, threshold, door bottom sweep and the peripheral structural elements of the door leaf, in a plane parallel to the door core surface. See Figure 4-1, Figure 4-2, Figure 5-1, Figure 5-2 and Figure 5-3.

Lite frame area (A_{lf}): specific to doors, the projected area extending from the sight line of the lite frame into the surrounding homogeneous door core surface for a distance of 25 mm (1 in.) beyond the outer edge of the lite frame and parallel to the door core surface. See Figure 5-1, Figure 5-2 and Figure 5-3.

Panel area (A_p): the projected area of all decorative panels of uniform thickness and extending from a point 25 mm (1 in.) of uniform thickness, in a plane parallel

to the door core surface. See Figure 4-1, Figure 4-2, Figure 5-1, Figure 5-2, Figure 5-3, Figure 5-11 and Figure 5-12.

Projected fenestration product area (A_{pt}): the area of the rough opening in the wall or roof, for the fenestration product, less installation clearances.

[**Note 1.**: Where a fenestration product has glazed surfaces facing in only one direction (typical products), the sum of the edge-of-divider area, the edge-of-glazing area, the divider area, the center-of-glazing area and the frame area will equal the total projected fenestration product area (A_{pt}). Where a fenestration product has glazed surfaces in more than one direction (e.g., greenhouse/garden, bay/bow windows) the sum of the areas will exceed the projected fenestration product area.]

Total fenestration product area (A): the area of the total fenestration product that includes all frame, divider, edge-of-glazing, edge-of-divider and center-of-glazing areas.

Awning window: a window with one or more sash that rotate about its top hinge and projects outward.

Baseline product: within a product line, the individual product selected for validation testing. To verify door glazing and lite frame simulations, the baseline product for door and sidelite product lines, which include glazed options, shall include glazing.

Base profile: primary structural member of a fenestration product line, which forms the basis for comparison, such as groupings.

Basement window: a window usually with one sash that projects inward and intended to be used at or below grade. Rated as the appropriate product type.

Bay window: a combination assembly which is composed of two or more individual windows joined side by side and which projects away from the wall on which it is installed. Center windows, if used are parallel to the wall on which the bay is installed. The two side windows are angled with respect to the center window(s). Common angles are 30° and 45°, although other angles are sometime employed. Individual windows are rated as the appropriate product type.

Bow window: a rounded bay window that projects from a wall in the shape of an arc. Individual windows rated as the appropriate product type.

Caming: material that divides and holds pieces of glazing together to form a single decorative glazing panel.

Casement window: a window containing one or more sash hinged to open from the side, that project outward or inward from the plane of the window in a vertical plane. A conventional casement window has a sash that projects outward.

Cladding: an applied rigid or semi-rigid roll-formed or extruded covering that is placed over or attached to and follows the contour of the interior or exterior framing member for the primary purpose of protection from environmental elements and/or aesthetics and adds no structural integrity to the framing member.

Combination assembly: a window, door or skylight assembly formed by a combination of two or more separate units whose frames are mullied together.

Composite assembly: a window, door or skylight unit consisting of two or more sash or product types within a single frame and/or utilizing an integral mullion.

Curtain wall: any building wall, of any material, which carries no superimposed vertical load (a non-bearing wall).

Curtain wall system: that portion of the exterior wall which may consist entirely (or principally) of a combination of framing materials, glass and glazing, opaque in-fill and other surfacing materials supported by (or within) a framework, in varying percentages per the design of the system.

Decorative panel/Panel insert: a decorative raised molding that is inserted into a cut-out in an insulated door slab. Decorative panels are typically molded from a composite material. The gap between the two halves of the panel may be filled with an insulating material.

Divider: any vertical or horizontal bar used to separate glazing into multiple lites or placed in the gap between sheets of glazing. Dividers may be external or internal, may be removable or non-removable and may be real or simulated. Dividers may also be called grids, grilles or muntins.

Door leaf: the pivoted or swinging portion of a door system. Sometimes referred to as a door slab.

Composite (material) door: a door manufactured from skins molded from plastics, fiberglass compounds, compressed composites or other non-metallic materials. The door leaf may or may not incorporate a structural perimeter constructed from materials including, but not limited to wood, wood products, composites or other reinforcing materials. The core of the door leaf may be filled with materials including, but not limited to insulating polyurethanes, styrenes or honeycombs.

Steel door: a door manufactured from steel skins, which may be coated with paint, plastic, wood veneers or other finishes. The door leaf may or may not incorporate a structural perimeter including, but not limited to materials of wood, wood products, composites or other reinforcing materials. The core of the door leaf may be hollow or filled with material, including, but not limited to, insulating polyurethane's, styrene's or honeycombs.

Wood door: a door manufactured from solid wood, wood veneers, wood laminates or a combination thereof. Such doors are generally assembled from stiles, rails and panels, but may also be wood flush doors of solid or hollow core construction.

Aluminum door: a door manufactured from aluminum extrusions for the vertical stiles and horizontal rails with glazed panel area. Aluminum doors may also be flush doors manufactured with aluminum skins (exterior and interior sides) applied over the aluminum stiles and rails with an insulating core.

Door/slab/slab door/fixed panel: a side hinged attachment, greater than 600 mm (24 in.) in width, whose primary function is to allow human egress or non-operable panels greater than 700 mm (27 in.) in width.

Dual action window: a window that consists of a sash that tilts from the top and swings inward from the side.

Dynamic Glazing Product: Any fenestration product that has the fully reversible ability to change its performance properties, including U-factor, SHGC, or VT. This includes, but is not limited to, shading systems between the glazing layers and electronic or electrochemical switchable glass coatings or constructions.

Embossed/Raised panel: decorative areas on a door leaf. On a steel door these may be pressed into the steel skin or achieved by the application of plastics or other trim materials. On composite (material) doors these are usually molded into the door skin or may also be achieved by the use of surface applied trim. Wood doors usually incorporate thinner wood sections assembled into the stiles and rails.

[Note 2.: See Figure 5-4 for Typical 6-panel layout.]

Exterior door system: the total door system that includes all frame, lite frame, divider, edge-of-divider, edge-of-glazing, center-of-glazing, door core, edge-of-panel and panel areas. The door, slab or slab door together with the surrounding frame, weatherstrip, sill and sweep.

Fixed window: a window designed to be non-operable.

Frame (door): the structural members into which the door leaf is installed, including the hinge jamb, latch jamb, head, sill (threshold), door bottom sweep and perimeter weatherstrip.

Frame and sash: any structural member of the fenestration product, with the exception of muntins or other dividers, used to create true or artificial divided lites.

Full OFF/CLOSED Position: The orientation or condition of a Dynamic Glazing Product with a shading system between the glazing layers that allows the minimum Visible Transmittance (VT) within the design limitations of the product.

Full ON/OPEN Position: The orientation or condition of a Dynamic Glazing Product with a shading system between the glazing layers that allows the minimum Visible Transmittance (VT) within the design limitations of the product.

Glass: an elastic transparent material composed of silica (sand), soda (sodium carbonate) and lime (calcium carbonate) with small quantities of alumina, boric or magnesia oxides.

Glazing/Glazing in-fill: a generic term used to describe an infill material, such as glass, plastic or other transparent or translucent material, used to enclose openings in a building created by a specific framing system. Opaque in-fill panels are allowed to be substituted for glazing in any of the calculations in this document.

Glazing system: the assembly of the glazing, spacer and desiccant combined to be placed in the opening in a window, skylight, door or sidelite.

Greenhouse/Garden window: a window unit that consists of a three-dimensional, five-sided structure. Operating sash are allowed but not required. Typically rated as a unit. Greenhouse/Garden windows cannot be simulated at this time, but may be rated using the testing alternative (see Section 4.1.2).

Grouping: two or more products within a product line represented by the worst performing product.

Horizontal sliding window: a window that contains one or more manually operated sash that slide horizontally within a common frame. Operating sash (X) and a fixed lite (O) comprising a unit is termed a single slider (XO) or (OX). When two operating sash are separated by a fixed lite, the unit is termed a picture slide (XOX) or end vent. When an operating sash separates two fixed lites, the unit is termed a center slide (OXO). When two bi-parting sash are located at the center of the unit with the fixed lites at each end, the unit is termed a bi-part center slide (OXXO). When adjacent sash by-pass one another, the unit is termed a double slide (XX or XXO) or a double slide and vent (XXX).

Individual product: within a defined product line, any one specific product, of any size. See Section 4.2.2 for further details.

Lite: another term for a pane of glass. In this procedure used primarily with entry doors.

Model size: the size listed in Table 4-3 that is used to rate a fenestration product.

Mullion: a horizontal or vertical structural member connecting two or more products. Mullions may be of the following types:

Integral mullion: a member that is bounded at both ends by crossing frame members.

Combination mullion: a member formed by joining two or more individual fenestration products together without a mullion stiffener.

Reinforcing mullion: a member with an added continuous mullion stiffener and joining two or more individual fenestration products along the sides of the mullion stiffener.

Mullion stiffener: an additional reinforcing member used in a reinforcing mullion. Mullion stiffeners may be designed to carry the total load or may share the load with the adjacent framing members.

Obscure glass: glass having an image, pattern or texture that distorts the vision through the glass.

Opaque in-fill systems: curtain wall systems that include opaque and/or glazing systems supported by a frame network.

Outdoor air ventilator assembly (OAVA): a device, other than a sash unit, for the purpose of controlling the passage of air through a fenestration product. An OAVA shall not allow outside air access to cavities within the cross-sectional boundaries of the sash, frame or glazing.

Product line: a series of individual products of the same product type as defined in Table 4-3. See Section 4.2.1 for further details.

Product type: a designation used to distinguish between fenestration products based on fixed and operable sash and frame members.

[**Note 3.:** referred to as operator type in previous versions.]

Roof window: a window designed for sloped application that provides for in-reach operation or sash rotation to facilitate cleaning the exterior surfaces from the interior of the building.

Representative size: the actual size of a product specimen that is used for validation testing.

Sash: the portion of a fenestration assembly that is installed in a frame and includes the glazing, stiles and rails. Sash may be operating or fixed.

Sidelite: a fenestration product that is used as a companion product installed on one or both sides of a door. Sidelites may consist of a glazed frame or a non-operable sash within a frame and shall not exceed 700 mm (27 in.) in width. [Products that exceed 700 mm (27 in.) width are rated as fixed windows.]

Sight line: the line formed by the inner profile of an opaque member (frame, sash or divider) and the glazing in a plane perpendicular to the surface. (See Figure 4-4.)

Site-Built Products: fenestration products that are designed to be field glazed or field assembled units comprised of specified framing and glazing components including: operable and fixed windows, curtain walls, window walls, storefronts, sloped glazing and skylights.

Skylight: a sloped or horizontal application of a fenestration product in an out-of-reach application that allows for natural daylighting.

Slab Sidelite: a non-operable door leaf – (see def.) not to exceed 686 mm (27 in.) in width,

Sliding glass door: sliding glass doors contain one or more manually operated panels that slide horizontally within a common frame. Operating panel (X) and a fixed lite (O) comprising a unit is termed a single slider (XO) or (OX). When two operating panels are separated by a fixed lite, the unit is termed a picture slide (XOX) or end vent. When an operating panel separates two fixed lites, the unit is termed a center slide (OXO). When two bi-parting panels are located at the center of the unit with the fixed lites at each end, the unit is termed a bi-part center slide (OXXO). When adjacent panels by-pass one another, the unit is termed a double slide (XX or XXO) or a double slide and vent (XXX).

Sloped glazing: a multiple-lite glazed system (similar to a curtain wall) that is mounted at a slope greater than 15° from the vertical plane.

Structurally glazed framing: A method of glazing where framing members are generally not exposed to the exterior. (i.e. 2-sided or 4-sided structural glazed)

Sunroom/Solarium: a glazed envelope system that has one wall or a portion thereof, that opens to a primary structure and remaining walls which may include a number of fenestration systems, such as windows, doors, skylights, kneewalls, etc, in varying percentages per the design of the system.

Thermal break: a material of low thermal conductivity that is inserted between members of high conductivity in order to reduce the heat transfer. Thermal barrier material conductivity shall not be more than 0.52 W/mK (3.60 Btu·in./h·ft²·°F).

Thermally broken (TB) members: system members with a minimum of 5.30 mm (0.210 in.) separation provided by a low conductance material (where thermal conductivity ≤ 0.5 W/mK, (≤ 3.6 Btu·in./h·ft²·°F) or open air space between the interior and exterior surfaces. Examples of such systems include, but are not limited to, pour and de-bridged urethane systems, crimped-in-place plastic isolator systems and pressure glazed systems with intermittent fasteners.

[**Note 4:** Intermittent fasteners shall be manufacturer's standard. Nominal spacing of fasteners shall be 150 mm (6 in.) apart or greater.]

Thermally improved (TI) members: system members with a separation ≥ 1.60 mm (0.062 in.) separation provided by a material [where thermal conductivity ≤ 0.5 W/mK, (≤ 3.6 Btu·in./h·ft²·°F)] or open air space between the interior and exterior surfaces. Such systems include members with exposed interior or exterior trim attached with clips and all skip/debridged systems.

Transom: a non-operable fenestration product that is used as a companion product installed above a door. Transoms may consist of glazed frame or a non-operable sash within a frame. For purposes of complying with this procedure transoms shall not exceed 700 mm (27 in.) in height. [Products that exceed 700 mm (27 in.) in height are rated as fixed windows. Operable transoms are rated as the appropriate product type from Table 4-3.]

Tubular daylighting device (a.k.a. TDD): a device primarily designed to transmit daylight from a roof surface to an interior ceiling surface via a tubular conduit. The device consists of an exterior glazed weathering surface, a light transmitting tube with a reflective inside surface and an interior sealing device, such as a translucent ceiling panel.

U-Factor, Overall Thermal Transmittance (a.k.a. U-value): a measure of the heat transfer characteristics of a fenestration product under specific environmental conditions. The U-Factor multiplied by the interior-exterior temperature difference and by the projected fenestration product area yields the total heat transfer through the fenestration product due to conduction, convection and infrared radiation. The U-Factor is the heat transmission in a unit time through a unit area of a test specimen and its boundary air films, induced by a unit temperature difference between the environments on each side in W/m²K (Btu/h·ft²·°F).

Center-of-glazing U-Factor (U_c): the U-Factor representative of the center-of-glazing area.

Divider U-Factor (U_d): the U-Factor representative of the divider area.

Door core U-Factor (U_{dc}): the U-Factor representative of the door core area.

Edge-of-divider U-Factor (U_{de}): the U-Factor representative of the edge-of-divider area.

Edge-of-glazing U-Factor (U_e): the U-Factor representative of the edge-of-glazing area.

Edge-of-panel U-Factor (U_{ep}): the U-Factor representative of the edge-of-panel area.

End stile U-Factor (U_{es}): the U-Factor representative of the garage door end stile area.

Frame U-Factor (U_f): the U-Factor representative of the frame and sash area.

Lite frame U-Factor (U_{lf}): the U-Factor representative of the lite frame area.

Panel U-Factor (U_p): the U-Factor representative of the panel area.

Total fenestration product U-Factor (U_t): the U-Factor representative of the total system.

Validation matrix: two or more product lines whose U-Factor can be validated by a single test.

Vehicular access door (garage door): a door that is used for vehicular traffic at entrances of buildings, such as garages, loading docks, parking lots, factories and industrial plants, that is not generally used for pedestrian traffic, which includes vertical jamb tracks, all divider, edge-of-divider, edge-of-glazing, center-of-glazing, door panel core, edge-of-panel and stile (end cap) areas. Currently ratings in this procedure are for residential vehicular access doors only, ratings for commercial doors are under development.

Vertical sliding window: a window that contains at least one manually operated sash that slides vertically within a common frame. Operating sash (X) and a fixed sash (O) comprising a unit are called single hung windows and units with two operating sash (X/X) are called double hung windows.

Window wall: A type of curtain-glazed wall installed between floors (or between floor and roof) that is typically composed of vertical and horizontal framing members containing operable or ventilators, fixed lights or opaque panels or any combination thereof in varying percentages per the design of the system. Also referred to as strip window.

4. GENERAL

4.1 Compliance

Fenestration product ratings shall be determined following the procedure outlined in Section 4.1.1 in accordance with the criteria specified in Sections 4.2 through 4.8 as modified by applicable portions of Section 5.

4.1.1 Product Line Simulation and Testing

- A. Determine the representative size matrix of U-Factors. List all individual products and associated representative sizes (see Section 4.4) within a product line. The representative size matrix of U-Factors for a product line is given as follows:

Table 4-1: Representative Size Matrix of U-Factors

	U-Factor for Model Size
Individual Product #1	
.	
.	
.	
Last Individual Product	

- B. Compute the total fenestration product U-Factor for the baseline product in the representative size matrix of U-Factors. Using the approved total fenestration product U-Factor calculation procedure (see Section 4.3.4), compute the U-Factor for the baseline product (see Section 4.2.6).

[**Note 5.:** Compute as many U-Factors in this representative size matrix as is necessary to definitely determine the baseline product.]

- C. Test the baseline fenestration product using the approved total fenestration product U-Factor test procedure in Section 4.3.5.1.
- D. Validation of the simulation procedure. If the simulated and tested U-Factors for the baseline product are equivalent, as defined in Section 4.7.1, then the computational procedure presented in Section 4.1.3 shall be considered validated for all the products in the product line. The approved total fenestration product U-Factor calculation procedure presented in Section 4.3.4 shall then be used to determine U-Factors for the model size matrix of U-Factors of Section 4.5.1. These are the values that shall be reported. If the simulated and tested U-Factors for the baseline product are not equivalent, as defined in Section 4.7.1, then the alternative test procedure presented in Section 4.1.2 may be used for all products within the product line with written permission from NFRC.

4.1.2 Testing Alternative

If an individual product cannot be simulated in accordance with Section 4.3.4, the test procedure found in Section 4.3.5.1 shall be used to determine the U-Factors of the individual fenestration product(s) for the size defined in Table 4-3.

The test specimen size shall be the size with the lowest deviation determined from Equation 4-2. If the test specimen cannot be fabricated at the Table 4-3 size, the tested U-Factor shall be adjusted to the model size using the following:

$$U_{\text{mod}} = \frac{(U_{\text{rep}} A_{\text{rep}})}{A_{\text{mod}}} \quad \text{Equation 4-1}$$

Where:

- U_{mod} = *U-Factor at model size*
- U_{rep} = *U-Factor at representative size (test size)*
- A_{rep} = *area at representative size*
- A_{mod} = *area of model size*

4.1.3 Custom Product Rating

A custom product is an NFRC individual product, which meets all of the following criteria:

- A. A custom product shall be composed of unique frame/sash components not covered within an existing standard product line's U-Factor matrix.
- B. The specific configuration of a custom product shall not be offered publicly in a manufacturer's catalog or similar literature.
- C. Less than 500 units shall be produced annually or shall be produced as part of one purchase order.

U-Factors for custom products, which meet the criteria above, may be represented by U-Factor ratings generated for a similar stock individual product made of the same product type and materials. A simulation analysis from an NFRC-certified simulator employed by an NFRC-accredited simulation laboratory confirming that the custom product's U-Factor is equal to or lower than the stock product shall be provided to the NFRC or NFRC's designated representative.

4.1.4 Dynamic Glazing Product Rating

Products meeting the definition of a Dynamic Glazing Product shall be rated at their full ON/OPEN and full OFF/CLOSED. The manufacturer shall specify the appropriate procedure to achieve the stated positions. Rating procedures for these positions shall be the same as for non-Dynamic Glazing Products, as outlined in Section 4.1.1 or Section 4.1.2 as appropriate.

4.2 Product Lines and Individual Products

U-factors shall be determined for all individual products within a product line except as allowed in Section 4.2.4. All product lines shall be simulated separately.

4.2.1 Product Lines

A product line is a series of fenestration products of the same product type, as listed in Table 4-3, manufactured from the same profiles and components. The following changes are the only allowable exceptions within a product line:

- A. Overall fenestration product size.
- B. Center-of-glazing and edge-of-glazing characteristics such as glazing types and thicknesses, glazing coatings, tints and obscurity, gas-fills, gap widths, shading systems between glazing layers, dividers and spacers.
- C. Operating/non operating configurations, as defined in Table 4-3, including table footnotes.
- D. Changes to accommodate glazing unit variations. Limited to changes of geometry, number or material type to stops, beads, adhesives or gaskets designed to retain the glazing. Changes to frame and sash profiles are allowed to accommodate glazing unit variations. This provision does not allow for interior and exterior glazed products to be in the same product line.
- E. Frame/sash modifications made to accommodate operating hardware and reinforcement for the purpose of addressing higher/lower loads and stresses. Limited to changes that do not change the exterior perimeter shape of the assembled cross section.
- F. Frame or sash changes where one component is replaced by another component of the same physical shape with a thermal conductivity that does not differ by more than ten times the thermal conductivity of the original material.
- G. Clad products and unclad products can be incorporated into one product line.
- H. Changes to the frame profiles to allow for different installations. Limited to the following:
 - i. Any changes to interior/exterior appendages added to the main web of the frame that are removable or not exposed after product installation, i.e., nailing fins
 - ii. Changes in the width (dimension perpendicular to the plane of the glazing) of the main frame or main frame components to allow for installation in different wall thicknesses.
 - iii. Products manufactured in both in-swing and out-swing options.
- I. Any sightline changes due to:

- i. Lengthening or shortening existing walls.
 - ii. Components added or replaced for equal and unequal lite configuration options or;
 - iii. For the installation of an Outside Air Ventilator Assembly (OAVA).
 - iv. Changes to the frame profiles to allow for different installations including pocket or sloped sill configuration options and sill height modifications.
- J. Minor revisions made to the profiles for aesthetic purposes. Limited to changes in the size and shape of snap beads, stops, jamb extensions, dividers (including simulated and true divider lites), exterior trim caps on curtain walls, window walls and sloped glazing. Decorative elements such as grooves or beads formed in or applied to the frame or sash are also allowed.
- L. Addition, deletion or changes in hardware and reinforcement
- M. Changes to interior or exterior finishes or coatings
- N. Sealing characteristic variables and elements. Limited to changes in gaskets, sealants, adhesives or weather strips in the same profile. Profile changes to accommodate seal changes shall be allowed.

4.2.2 Individual Products

An individual product is any one specific combination of the product line variables (singularly or in combination) allowed in Section 4.2.1. All individual products shall be simulated except as allowed in Section 4.2.1.

The following changes are the only allowable exceptions to an individual product:

- A. Variations in frame or sash interior/exterior finish, paint, varnish or stain shall not constitute different individual products provided that each of these variations does not change the surface emittance by more than 0.1 or overall thickness by more than 0.400 mm (0.016 in.).
- B. Products with different variations in glazing divider patterns do not need to be treated as different individual products.
 - i. The manufacturer shall be permitted to define a standard glazing divider pattern (which shall be a standard product offering) which uses glazing dividers 300 mm (12 in.) on-center or less; or
 - ii. A glazing divider pattern with an on-center spacing closest to, but not greater than, 300 mm (12 in.) shall be designated as the glazing divider pattern.

- iii. The overall window dimension shall be used to determine the number of dividers.
- C. Fenestration products that include an outdoor air ventilator assembly (OAVA) shall be considered the same individual product if the OAVA projected dimension including any components to facilitate installation of the OAVA is less than or equal to 45 mm (1.75 in.). If this dimension exceeds 45 mm (1.75 in.) it shall be simulated as an individual product.
- D. Dynamic Glazing Products that include a shading system between glazing layers shall be considered individual products within the product line.

4.2.3 Validation Test Matrix

A Validation Test Matrix of multiple product lines of the same product type or multi-purpose products of different product types shall be permitted to be created.

4.2.3.1 Same Product Type

When the changes listed below are made, two or more product lines of the same product type, as listed in Table 4-3, shall be permitted to be included within the same Validation Test Matrix if the overall U-factor difference between the product lines is $\pm 0.06 \text{ W/m}^2\text{K}$ ($0.01 \text{ Btu/h}\cdot\text{ft}^2\cdot\text{°F}$) or less when simulated with the lowest center-of-glazing option.

- A. Changes to shift the location of the glazing relative to the sash or frame – exterior to interior.
- B. Changes to geometry or location of lift or pull handles.
- C. Product lines fabricated with both pocket and sloped sill options.
- D. Vinyl caps attached to the interior.

4.2.3.2 Multi-purpose products

Multi-purpose products incorporating nearly identical frame/sash base profiles shall be permitted to be within one validation matrix, provided that the differences between the base profiles are limited to minor changes to accommodate different product types. The minor changes allowed are:

- A. The movement or addition of specific elements (i.e. walls & cavities) to accommodate the differing operating hardware.
- B. Adding or deleting components to adapt a channeled frame to use a tilt sash.

- C. The use of the hung window sash stiles as the bottom rail.
- D. Deleting of the roller track of the horizontal slider.
- E. The addition of sash balance covers.
- F. Any other component changes that occur as a direct result of the hardware changes.

Any elements added to the profile to accommodate operating hardware shall be of the same material types used in the original profile.

4.2.4 Grouping of Products

This section presents rules that shall be permitted to reduce the number of simulations for individual products that represent a product line. If this approach is used, the total fenestration product U-factor for the group leader shall be used to represent the total fenestration product U-factors for all individual products within that group. These grouping rules shall not be used to group individual products from different product lines into one product line.

To ensure consistent ratings, groupings shall be done in the following order:

Center-of-glazing	4.2.4.1
Shading systems between glazing layers	4.2.4.2
Spacer	4.2.4.3
Divider	4.2.4.4
Frame/Sash	4.2.4.5

Any combination of groupings shall be done in the order established above. All grouping comparisons shall be based on three significant digits.

4.2.4.1 Center-of-Glazing Grouping

- A. For the purpose of determining U-factors, center-of-glazing groups shall consist only of variations in glazing thickness, gap width, gas fill and low-E coatings and the presence or absence of internal grids. Once all center-of-glazing options have been identified within a product line, the center-of-glazing U-factor shall be simulated for each option. Then, these products shall be permitted to be grouped with each group represented by the center-of-glazing group leader, which shall be the center-of-glazing option with the highest center-of-glazing U-factor.
- B. Glazing options with different numbers of glazing layers shall not be grouped together.

- C. Glazing options with clear glazing in all layers shall not be grouped with glazing options with one or more low-E layers (e is less than or equal to 0.50).
- D. Only individual products that contain the same mixture of gases shall be permitted to be grouped. Variable concentrations of the same mixture of gases shall be permitted to be grouped as a center-of-glazing grouping as long as the total gas concentration, other than air, is more than 60 percent and does not vary by more than ± 10 percent from the group leader.

4.2.4.2 Grouping of Shading Systems between Glazing Layers

When rating Dynamic Glazing Products with shading systems between glazing layers, it shall be permitted to group combinations of shading systems and glazing layers. For purposes of determining U-factors, the shading system and glazing layers comprising each group leader shall be determined as follows:

- A. Shading systems within a group shall vary only by color of the shading systems. The shading system used in the group leader shall be permitted to be of any color.
- B. Glazing layers within a group, and the corresponding glazing layers used in the group leader, shall be determined in accordance with the center-of-glazing grouping rules of Section 4.2.4.1.

4.2.4.3 Spacer Grouping

For the purpose of determining U-factors, spacer groups shall consist only of variations in spacer assembly materials and shapes. After all spacer options have been identified within a product line, the frame and edge-of-glazing heat loss shall be simulated for each spacer option with the lowest center-of-glazing U-factor in the product line. These products shall be permitted to be grouped with each group represented by the spacer group leader, which shall be the option with the highest whole product heat loss. If this approach is used, the total fenestration product U-factor for the spacer group leader shall be used to represent the total fenestration product U-factors for all individual products within that group.

4.2.4.4 Divider Grouping

- A. For the purpose of determining U-factors, divider groups shall consist only of variations in divider materials and shapes. After all divider options have

been identified within a product line, the frame and edge-of-glazing heat loss shall be simulated for each grid option with the lowest center-of-glazing U-factor in the product line. These products shall be permitted to be grouped with each group represented by the divider group leader, which shall be the divider option with the highest whole product heat loss. If this approach is used, the total fenestration product U-factor for the divider group leader shall be used to represent the total fenestration product U-factors for all individual products within that divider group.

- B. Products with glazing dividers between layers of an IG unit shall be permitted to be assumed to have the same U-factors as identical products without such dividers, providing there is at least 3.00 mm (0.118 in.) air/gas space between the divider and both adjacent glazing surfaces.

4.2.4.5 Frame Grouping

For the purpose of determining U-factors, frame groups shall consist only of frame/sash base profile variations consistent with the definition of a product line. After all frame options have been identified within a product line, the frame and edge-of-glazing heat loss shall be simulated for each option with the lowest center-of-glazing U-factor in the product line. The frame group leader shall be identified as the set of frame options with the highest whole product heat loss. If this approach is used, the total fenestration product U-factor for the frame group leader shall be used to represent the total fenestration product U-factors for all individual products within that group.

The only allowable exceptions within a frame group are:

- A. Individual products with different sightlines, simulated as separate individual products in the product line.

4.2.5 General Simulation Rules

- A. If a nail flange is not removable, and is identified as such by the manufacturer, the product shall be simulated and tested with the nail flange covered with a nominal "1 by 4" fir trim. If a nail flange is removable, the product shall be simulated and tested without the nail flange.
- B. Products with integral appendages that extend beyond the rough opening and are not exposed after installation shall be permitted to

be assumed to have the same U-factors as identical products without such appendages.

- C. Nominal glass thickness shall be permitted to be used for determining U-factor, provided the emissivity of the glass is taken from the approved NFRC Spectral data file and the air gap dimension is maintained at the dimensions specified by the manufacturer. The nominal glass thickness to be used shall be listed in ASTM C 1036-02.
- D. An infill system with a “Center-of-Glazing Component Test” which utilizes an adaptor between the infill and frame that allows for direct replacement of the standard glazing, shall be considered an individual product in the same product line with the standard glazing, as long as all components, including the adaptor, are included in the simulation for the infill glazing system.
- E. Non-rectangular fenestration products shall be rated as rectangular fenestration products per the standard size in Table 4-3. Develop a product line with the same frame cross sections as the non-rectangular fenestration product.
- F. IG units manufactured with breather or capillary tubes designed to remain closed after manufacturing shall be simulated as having the same gas content. IG units manufactured with breather tubes intended to be opened at some point after manufacturing shall be simulated as air-filled IG units.
 - i. For the purpose of determining U-factors, only glazing tint and/or obscurity (including obscure glass, fritted glass or wired glass) shall be permitted to be assumed to have the same U-factor as the clear glass and does not need to be simulated separately unless this change is associated with a change in coating properties.
 - ii. Products with removable or non-removable dividers or decorative tapes, that are applied to glazing to simulate the appearance of dividers applied to the room side and/or exterior side glazing surface, shall be permitted to be assumed to have the same U-factors as identical products without such divers.

4.2.6 General testing rules

The baseline product shall be the individual product selected for validation testing (see Section 4.1.1). The individual product selected as the baseline product shall have a simulated U-factor within $0.60 \text{ W/m}^2\text{K}$ ($0.10 \text{ Btu/h}\cdot\text{ft}^2\cdot\text{°F}$) or twenty percent of the lowest simulated U-factor, whichever is greater. Size variations shall be limited to the representative size as defined in Section 4.6.1 for the product type. If more than one

product type is being validated with a single test, then the baseline product shall be selected from the product lines in the validation test matrix.

4.2.7 General rating rules

Combination products shall not be rated in combination.

4.2.8 Additions to the Product Line

The product line validated simulation procedure (see Section 4.1.1) may be used to determine U-factors of additions to a validated product line if the simulated U-factor for the additional product(s) is either higher than the previously computed baseline product U-factor, or not more than $0.60 \text{ W/m}^2\text{K}$ ($0.10 \text{ Btu/h}\cdot\text{ft}^2\cdot\text{°F}$) or twenty percent (whichever is greater) lower than a previous simulated baseline product U-factor.

If the simulated U-factor of the addition to the product line is outside these bounds, a new baseline product shall be established and validated by testing.

If a manufacturer introduces a new individual product into multiple product lines (see Section 4.2.6 for an example of glazing or spacer options) that has simulated U-factor more than $0.60 \text{ W/m}^2\text{K}$ ($0.10 \text{ Btu/h}\cdot\text{ft}^2\cdot\text{°F}$) or twenty percent lower than the simulated baseline product U-factor, only one product line with a new individual product shall be tested. If the simulation of the new baseline product validates, then all other product lines using this option shall be validated and those new individual products shall be permitted to be simulated to obtain U-factors.

4.3 Standard Conditions

This section presents standard simulations, tests and calculations for determining total or component fenestration product U-Factors.

4.3.4 Simulation

The requirements of Reference 2 of the NFRC Simulation Manual and of Section 4.3.5.1 shall be used to determine total fenestration product U-Factors.

Skylights and other sloped glazing products shall be simulated and rated at a slope of 20 degrees above the horizontal. Tubular daylighting devices shall be simulated and rated with the tube in a vertical orientation (Figure 5-10). All other products shall be simulated and rated in the vertical position.

All calculations shall be based on computer simulations using the latest approved software which shall be in compliance with ISO 15099, with the following exceptions:

- A. For calculating the overall U-Factor per ISO 15099, the area-weighted method as described in Section 4.1.3 of ISO 15099 shall be the only method permitted.
- B. Thermo-Physical properties of materials shall be determined in accordance with NFRC 101.
- C. Section 7 in ISO 15099 on Shading Systems is currently excluded from NFRC procedures.
- D. Section 8.2 in ISO 15099 addresses environmental conditions. The following conditions shall be used for the determination of U-Factor:

NFRC Simulation Conditions:

$$\begin{aligned}
 T_{in} &= \text{interior ambient temperature of } 21.0^{\circ}\text{C (69.8}^{\circ}\text{F)} \\
 T_{out} &= \text{exterior ambient temperature of } -18.0^{\circ}\text{C (-0.4}^{\circ}\text{F)} \\
 V &= \text{wind speed of } 5.5 \text{ m/s (12.3 mph)} \\
 T_{rm,out} &= T_{out} \\
 T_{rm,in} &= T_{in} \\
 I_s &= 0 \text{ W/m}^2 \text{ (0 Btu/h}\cdot\text{ft}^2\text{)}
 \end{aligned}$$

- E. Section 8.3 in ISO 15099 addresses convective film coefficients on the interior and exterior of the window product.
- F. The indoor side convective heat transfer coefficient shall be based on the center of glass temperature and the entire window height; this film coefficient shall be used on all glass and edge of glass indoor surfaces. Frame section indoor convective film coefficients shall be constants, which depend on frame material type; these values are listed in Table 4-2.
- G. The outdoor side convective heat transfer coefficient shall be calculated based on wind speed as defined under the sub clause e) and shall be applied to all of outdoor surface, glass and frame. Standard values for outdoor convective surface heat transfer coefficients is listed in Table 4-2.
- H. On the indoor side of a fenestration product, detailed radiation model, based on gray body radiation model as described in Section 8.4.2.1 (Two-Dimensional Element To Element View Factor Based Radiation Heat Transfer Calculation) in ISO 15099, shall be used for all products. This model applies to both glass and frame surfaces.
- I. The use of detailed radiation model on indoor fenestration surfaces makes the use of “slightly or partially ventilated cavities” on the indoor frame surfaces redundant (see Section 6.7.1 of ISO 15099). The standard frame convective film coefficients (hc) shown in Table 4-2 and detailed radiation model referenced above shall thus be applied to all interior frame surfaces.

- J. On the outdoor side of a fenestration product, black body radiation model, as defined in ISO 15099 shall be used. This model applies to both glass and frame surfaces.
- H. All cross-sections shall include 150 mm (6 in.) of glazing section from the sightline to the end of the glazing section, while maintaining a 63.5 mm (2.5 in.) edge-of-glazing dimension.

Table 4-2: Boundary Conditions

Boundary Condition	Radiation Model	Convective Film Coefficient Boundary	
		Tilt = 90° W/m ² K (Btu/h·ft ² ·°F)	Tilt = 20° W/m ² K (Btu/h·ft ² ·°F)
NFRC 100-2001 Exterior	Blackbody	26.00 (4.578)	26.00 (4.578)
Interior Aluminum Frame (convection only)	Gray Body Diffuse	3.29 (0.579)	4.94 (0.869)
Interior Thermally Broken Frame (convection only)	Gray Body Diffuse	3.00 (0.528)	4.38 (0.771)
Interior Thermally Improved Frame (convection only)	Gray Body Diffuse	3.12 (0.549)	4.60 (0.810)
Interior Wood/Vinyl Frame (convection only)	Gray Body Diffuse	2.44 (0.429)	3.38 (0.595)
Interior Glazing System boundary condition	Gray Body Diffuse	Calculated by WINDOW for each glazing configuration using formulas in Section 8.3.2 in ISO 15099	

4.3.5 Testing

4.3.5.1 Total Fenestration Product Test Procedure

The NFRC 102: Procedure for Measuring the Steady-State Thermal Transmittance of Fenestration Systems [Reference 1], shall be used to determine tested total fenestration product U-Factors. The following conditions also apply:

- A. Test specimen size tested shall be in accordance with Section 4.6.1.
- B. All test specimens shall be tested without screens, removable grilles and trims or any other applied devices.
- C. All test specimens shall be tested in the vertical position. For determining validation of the baseline product only,

skylights and other sloped glazing products, shall be simulated in a vertical position; and

- D. The test specimen shall not be modified by the testing laboratory, except as allowed in Reference 1 for sealing against air leakage and as required in this section.

4.3.5.2 Center-of-Glazing Component Test Procedure

If the U-Factor for the product cannot be simulated in accordance with Section 4.3.4, the test methods in Reference 6, using NFRC environmental conditions, shall be used to determine the conductance of the center-of-glazing. Standard film coefficients listed in NFRC Test Procedure shall then be used to calculate the center-of-glazing U-Factor. This value shall be used in appropriate equation to calculate total product U-Factor.

4.3.5.3 Component Substitution

Component substitutions may be made if using approved NFRC simulation tools to verify the performance equivalence to three significant digits. The original certified U-Factors shall be used to represent the new product.

For products certified under the Testing Alternative Method, Section 4.1.2, component substitution shall apply only if the simulation laboratory states in the simulation report that the simulation tools are appropriate for the simulation of the components being substituted.

- A. For spacer substitutions, only the spacer shall be modeled.
- B. For glazing system changes, only the center-of-glazing shall be modeled.

4.4 Model Sizes and Configurations

For each individual product, total fenestration product U-Factors shall be reported for the specified configuration at the model size as shown in Table 4-3.

For products that, when area-weighted at the standard NFRC size, have less than 63.5 mm (2.5 in.) edge-of-glazing area or edge-of-divider area, the product shall be area-weighted with each section (including dividers) at the manufacturer's standard frame height (pfd) plus 63.5 mm (2.5 in.) of edge-of-glazing. The increase in size should result in zero center-of-glass area.

Table 4-3: Product Types and Model Sizes

Product Type	Opening (X) Non-operating (O)	Model Size (width by height)
		SI (IP)
Casement – Double ¹	XX	1200 mm by 1500 mm (47 in. by 59 in.)
Casement – Single	X	600 mm by 1500 mm (24 in. by 59 in.)
Dual Action	X	1200mm by 1500 mm (47 in. by 59 in.)
Fixed (includes non-standard shapes)	O	1200 mm by 1500 mm (47 in. by 59 in.)
Garage Door ²	X	3000 mm by 2400 mm (118 in. by 94 in.)
Greenhouse/Garden ³	X	1500 mm by 1200 mm (59 in. by 41 in.)
Hinged Escape	X	1500 mm by 1200 mm (59 in. by 47 in.)
Horizontal Slider	XO or XX	1500 mm by 1200 mm (59 in. by 47 in.)
Jal/Jal awning	X	1200 mm by 1500 mm (47 in. by 59 in.)
Pivoted	X	1200 mm by 1500 mm (47 in. by 59 in.)
Projecting (Awning, Dual)	XX	1500 mm by 1200 mm (59 in. by 47 in.)
Projecting (Awning – Single)	X	1500 mm by 600 mm (59 in. by 24 in.)
Sidelite ³	X	600 mm by 2000 mm (24 in. by 79 in.)
Skylight/roof window	X ⁴	1200 mm by 1200 mm (47 in. by 47 in.)
Sliding Patio Door with Frame	XO or XX	2000 mm by 2000 mm (79 in. by 79 in.)
Glazed Wall/Sloped Glazing	OO ⁵	2000 mm by 2000 mm (79 in. by 79 in.)
Swinging Door with Frame	O, X, XO or XX ⁶	1000 mm by 2000 mm (39 in. by 79 in.) or 2000 mm by 2000 mm (79 in. by 79 in.)
Door Transom ³	X	2000 mm by 600 mm (79 in. by 24 in.)
Tropical Awning	X	1500 mm by 1200 mm (59 in. by 47 in.)
Tubular Daylighting Device	O	350 mm Dia. (14 in. Dia.)
Vertical Slider	XO or XX	1200 mm by 1500 mm (47 in. by 59 in.)

¹ Double Casements are to be rated only in the case where single casement is not manufactured.

² When ratings are determined by physical testing, test samples are allowed to be 2400 mm by 2400 mm (94 in. by 94 in.) if the test chamber cannot handle the size listed in Table 4-3.

³ If not manufactured, use O (fixed unit).

⁴ Fits over or in a 1180 mm by 1180 mm (46.5 in. by 46.5 in.) opening.

⁵ Two lites with one vertical mullion. Curtain walls shall be simulated and tested with intermediate verticals as jambs and intermediate horizontals as head/sill frame members. Window walls shall be simulated and tested with intermediate verticals as jambs and standard head and sill members. For rating of curtain walls and window walls, area weight intermediate members based on centerline dimensions. Glazed wall and sloped glazing shall be simulated and tested with standard jamb, head, and sill members (see Section 5.6).

⁶ The single door shall be used to represent all door assemblies (single, double, multiple) unless the manufacturer does not produce a single door, in that case the double door shall be used to represent double and multiple door assemblies.

4.5 Simulation Procedures

4.5.1 Total Fenestration Product U-Factors for Model Sizes

For a given product line, list all individual products and the associated model size U-Factors (see Section 4.4). The model size matrix of U-Factors for a given product line shall be outlined as shown in Table 4-1.

This matrix shall include all individual products within a product line which are available from the manufacturer, including, but not limited to, the number of glazing layers, glazing types, glazing coatings, gas-fills, gap widths, spacer types and use of dividers. See Section 4.2.1 for the definition of a product line and Section 4.2.2 for the definition of individual products.

In order to determine total fenestration product U-Factors for all the entries in this matrix, use the product line validated simulation procedure, presented in Section 4.1.1. The testing alternative, presented in Section 4.1.2, may only be used to determine the U-Factor for an individual product(s) within a product line if that individual product(s) cannot be simulated in accordance with Section 4.3.4.

Thus, the only time a product line may contain tested as well as simulated total fenestration product U-Factors shall be when an accredited simulation laboratory states in the simulation report that it cannot simulate an individual product(s) to a reasonable accuracy. In addition, the written permission of NFRC shall be required.

4.5.2 Total Fenestration Product

The U-Factor of a fenestration product may vary by size, depending upon the component materials and the glazing. To simplify the system, ratings are based on a specific model size. The U-Factor for the model size in Table 4-3 shall be representative of all variations in configuration with dual or more lites (opening/non-opening) for the product type, except as indicated in any applicable footnote. The U-Factor for the model size shall be representative of all variations in size and factory assembled operable and fixed units in a common frame.

For gas fills other than air, the gas fill percentages used in the simulations shall not exceed the values in Reference 2 for a given filling technique.

Non-continuous elements, including, but not limited to, screws and bolts in sloped glazing and poured and debridged thermal barriers which are not fully debridged, shall be simulated as indicated in Reference 2.

The total fenestration product U-Factor calculation procedure can be found in the applicable fenestration product section, see Sections 5.1 to 5.6.

4.5.3 Component

4.5.3.1 Approved Center-of-Glazing Simulation Programs

Approved center-of-glazing software shall be used. NFRC approved software is listed in Reference 5.

4.5.3.2 Approved 2-D Heat Transfer Simulation Programs

Approved 2-D heat-transfer software shall be used. NFRC approved software is listed in Reference 5.

4.6 Test Procedures

There are two different test procedures used in NFRC 100:

- Total Fenestration Product 4.6.1 and
- Glazing Component Test Procedure 4.6.2.1.

Section 4.3.5.1 defines the total fenestration product test procedure, its standard conditions and requirements. The total fenestration product test procedure shall be used to validate the product line simulations (see Section 4.1.1) and shall be used under the testing alternative (see Section 4.1.2), which shall be used only if the U-Factor for the product cannot be simulated in accordance with Section 4.3.4. Section 4.3.5.2 defines a glazing component test procedure, which may be used only if the U-Factor for the center-of-glazing cannot be simulated in accordance with Section 4.3.4. Since the glazing system may include non-homogeneous elements (e.g. spacers, thermal bridges, etc.), an average conductance shall be assigned to the whole glazing system. Insertion of such a glazing system in the 2-D heat transfer program shall be done as a continuous slab of material with the conductivity equal to the average conductivity of the glazing system.

4.6.1 Total Fenestration Product

For the purposes of testing (see Section 4.3.5), production line units and sizes shall be used. The test specimen size shall be the production line size with the least deviation (D) from the model size (see Table 4-3) as defined by Equation 4-2:

$$D = \sqrt{(W_p - W_m)^2 + (H_p - H_m)^2} \quad \text{Equation 4-2}$$

Where

- D = deviation in mm (in.)
- W_p, H_p = width, height of production size in mm (in.)
- W_m, H_m = width, height of model size in mm (in.)

For rectangular fenestration products, the representative sizes reported by the simulation laboratory shall not vary by more than 13.0 mm (0.5 in.) in

width or 13.0 mm (0.5 in.) in height [25 mm (1 in.) for doors] from the reported sizes of the tested specimens.

For non-rectangular products, the simulated product area shall meet the following relationship with the tested specimen area:

$$A_{test} - C(W_m + H_m) \leq A_{sim} \leq A_{test} + C(W_m + H_m) \quad \text{Equation 4-3}$$

Where

$$\begin{aligned} A_{sim} &= \text{area of product simulated in } mm^2 \text{ (in.}^2\text{)} \\ A_{test} &= \text{area of specimen tested in } mm^2 \text{ (in.}^2\text{)} \\ C &= \text{a constant, 25 mm (1 in.)} \\ W_m, H_m &= \text{width, height of model size in mm (in.)} \end{aligned}$$

4.6.2 Component

4.6.2.1 Glazing Component Test Procedure

The test methods in Reference 6, using NFRC environmental conditions, shall be used to determine the average conductivity of the glazing.

4.6.3 Calculation Procedure

The total fenestration product U-Factor shall be calculated as outlined below:

- A. Determine all of the following, as applicable:
 - i. Center-of-glazing U-Factor per the total product height procedure as defined in Reference 2 using an approved center-of-glazing simulation program or the approved glazing test procedure given in Section 4.3.5.2.
 - ii. Edge-of-glazing U-Factor using an approved 2-D heat transfer simulation program. In the case that center-of-glass thermal performance is simulated, this center-of-glass configuration shall be inserted into the frame and spacer assembly shall be added. In the case that the glazing component test procedure had to be utilized, entire glazing system shall be represented as an homogenous slab of material with conductivity equal to average conductivity of the measured specimen. For mullions and meeting rails, two glazing systems shall be inserted on each end and reported U-Factor shall be the average of the two edge-of-glass U-Factors.
 - iii. Divider U-Factor using an approved 2-D heat transfer simulation program. Divider shall be simulated with two

glazing systems pointing in opposite directions, simulated in a vertical orientation.

- iv. Edge-of-divider U-Factor using an approved 2-D heat transfer simulation program. Edge-of-divider U-Factor shall be the average of the two edge-of-glass section U-Factors.
- v. Frame U-Factor using an approved 2-D heat transfer simulation program. Frame U-Factor is always calculated on the exposed indoor size of frame, starting at the bottom of the frame and ending at the indoor sight line. For mullion and meeting rail cross-sections, frame surface is counted from one indoor sight line to another.
- vi. The component areas of:
 - (a) Center-of-glazing area
 - (b) Edge-of-glazing area
 - (c) Divider area
 - (d) Edge-of-divider
 - (e) Frame area
 - (f) Projected fenestration product area.

B. Perform the following calculations as explained:

- i. Multiply the center-of-glazing, edge-of-glazing, divider, edge-of-divider and frame U-Factors by their corresponding areas.
- ii. Total these quantities; and
- iii. Divide this total by the projected fenestration product area to produce simulated total fenestration product U-Factors for all the fenestration products in the matrix of required U-Factors.

4.6.4 Reporting of Ratings

The U-Factor shall be reported to 0.05 W/m²K (0.01 Btu/h·ft²·°F). If area-weighting is done, software full floating point accuracy shall be used and the final U-Factor shall be rounded to two digits following the decimal point. If a spreadsheet or hand calculations are required, all variables used in the formula shall be expressed to at least three significant decimal places and the final U-Factor rounded to two digits beyond the decimal point.

4.7 Validation

4.7.1 Equivalence

Simulated and tested U-Factors for a given total fenestration product shall be considered equivalent if the agreement between the two numbers is within the ranges in Table 5-1.

Table 4-4 Equivalence

Simulated U-Factor	Accepted Difference Between Tested and Simulated U-Factor
1.7 W/m ² K (0.3 Btu/h·ft ² ·°F) or less	0.17 W/m ² K (0.03 Btu/h·ft ² ·°F) or less
Greater than 1.7 W/m ² K (0.3 Btu/h·ft ² ·°F)	10% of Simulated U-Factor

Figure 4-2 Fenestration Product Schematic-Vertical Section

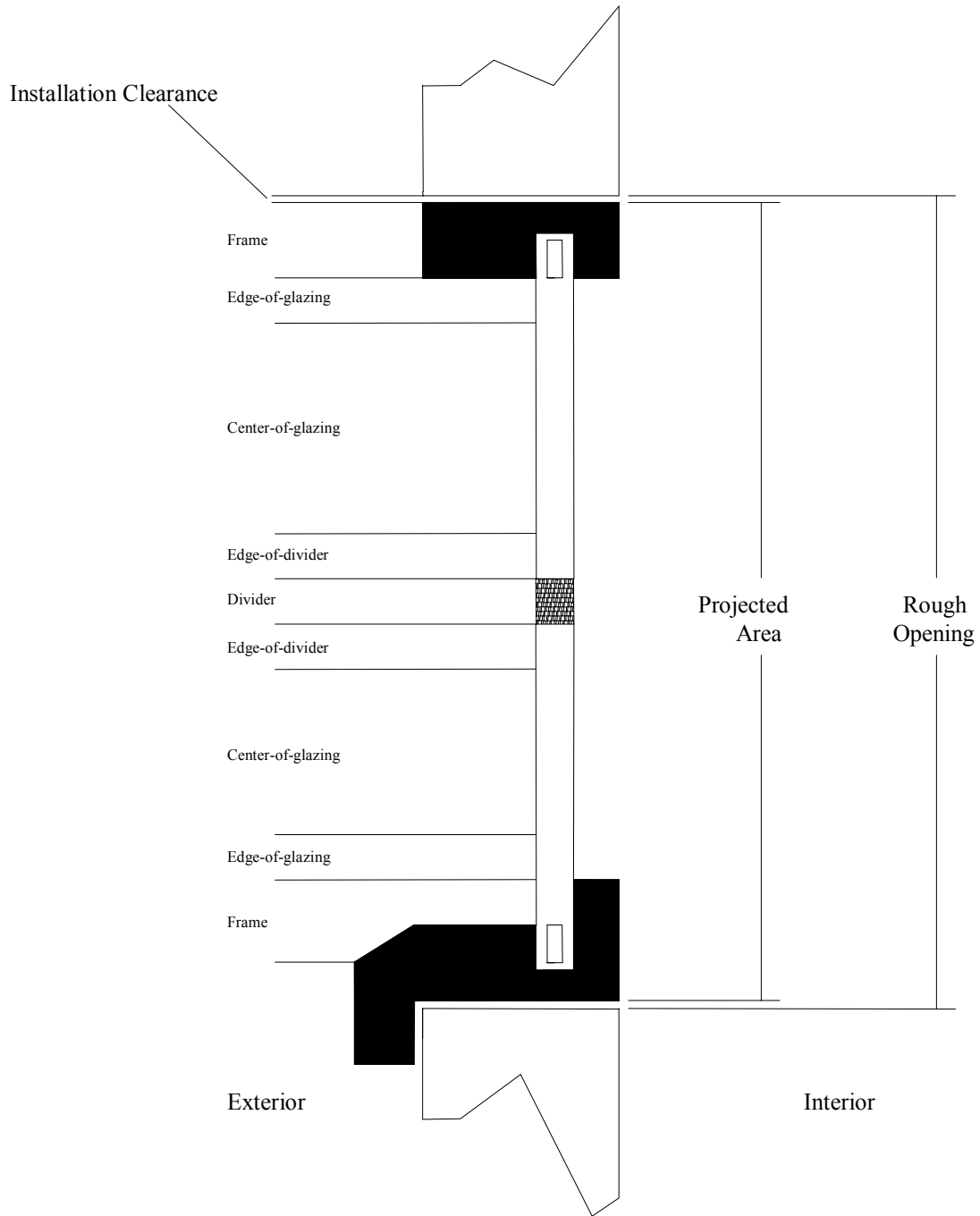

Center-of-glazing, edge-of-glazing, divider, edge-of-divider and frame areas for a typical fenestration product. Edge-of-glazing and edge-of-divider are 63.5 mm (2.5 in.) wide. The projected fenestration product area is the rough opening less installation clearances..

Figure 4-3 Divider Height and Divider Width

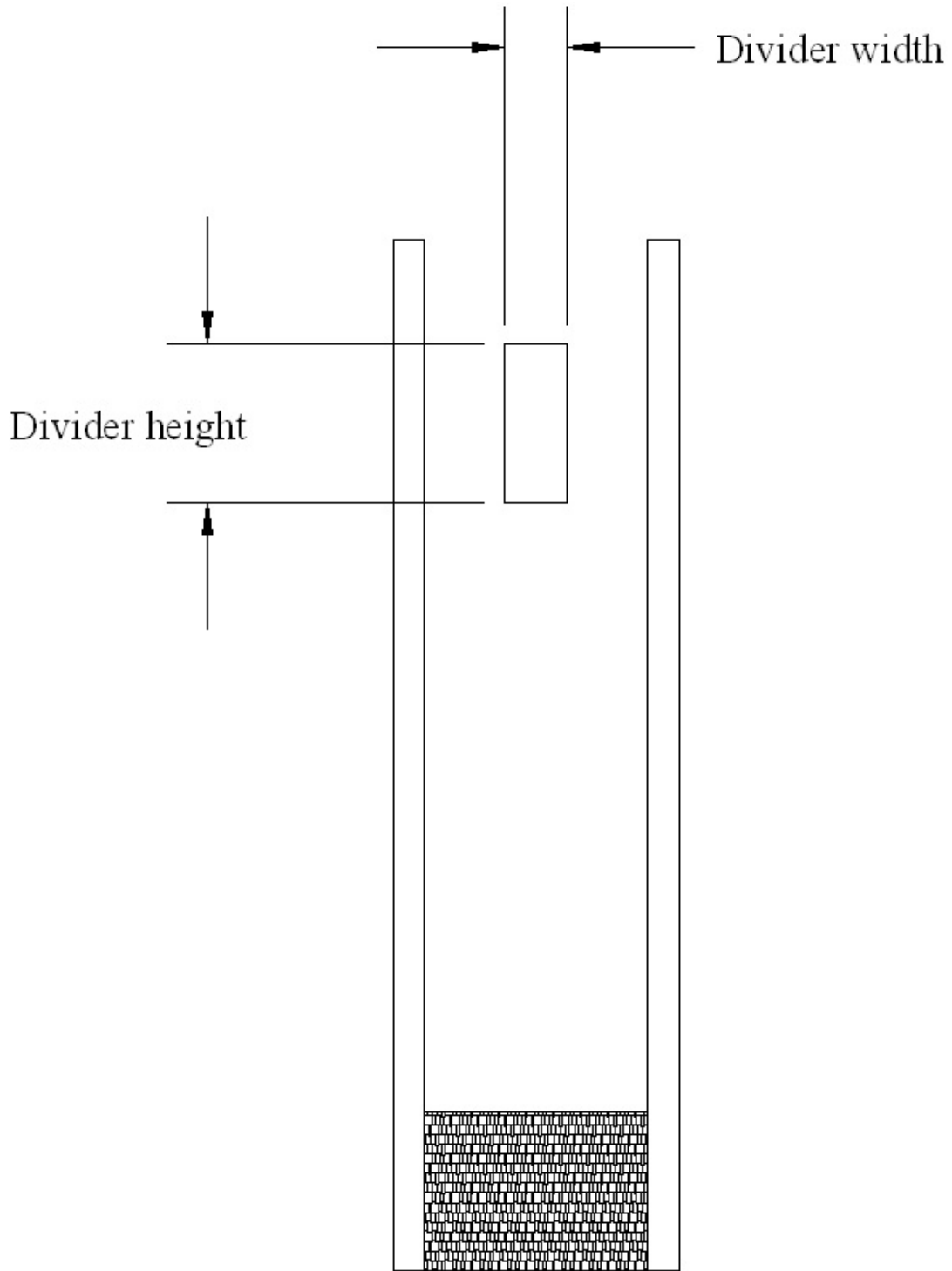

Figure 4-4 Sightline Examples

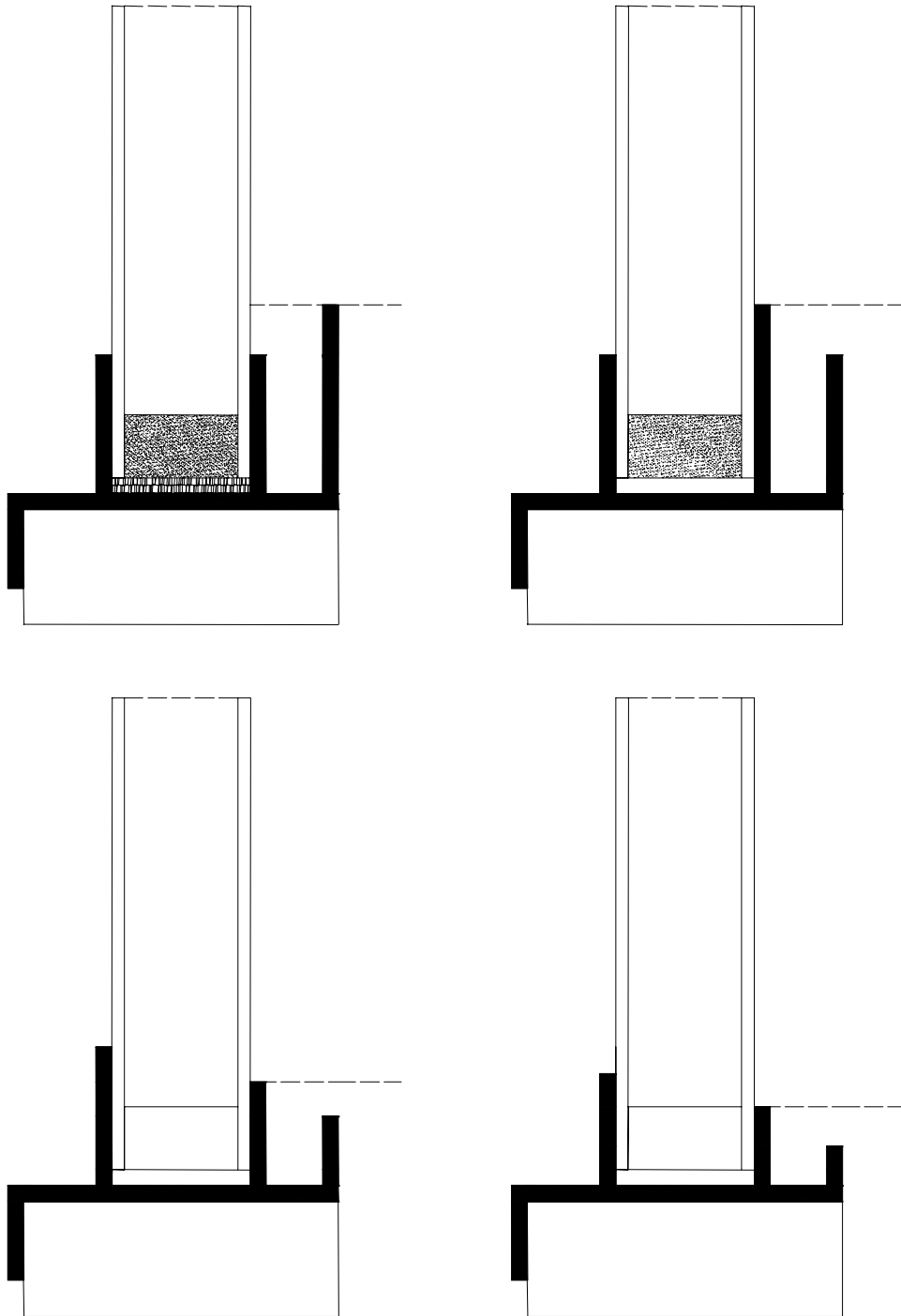
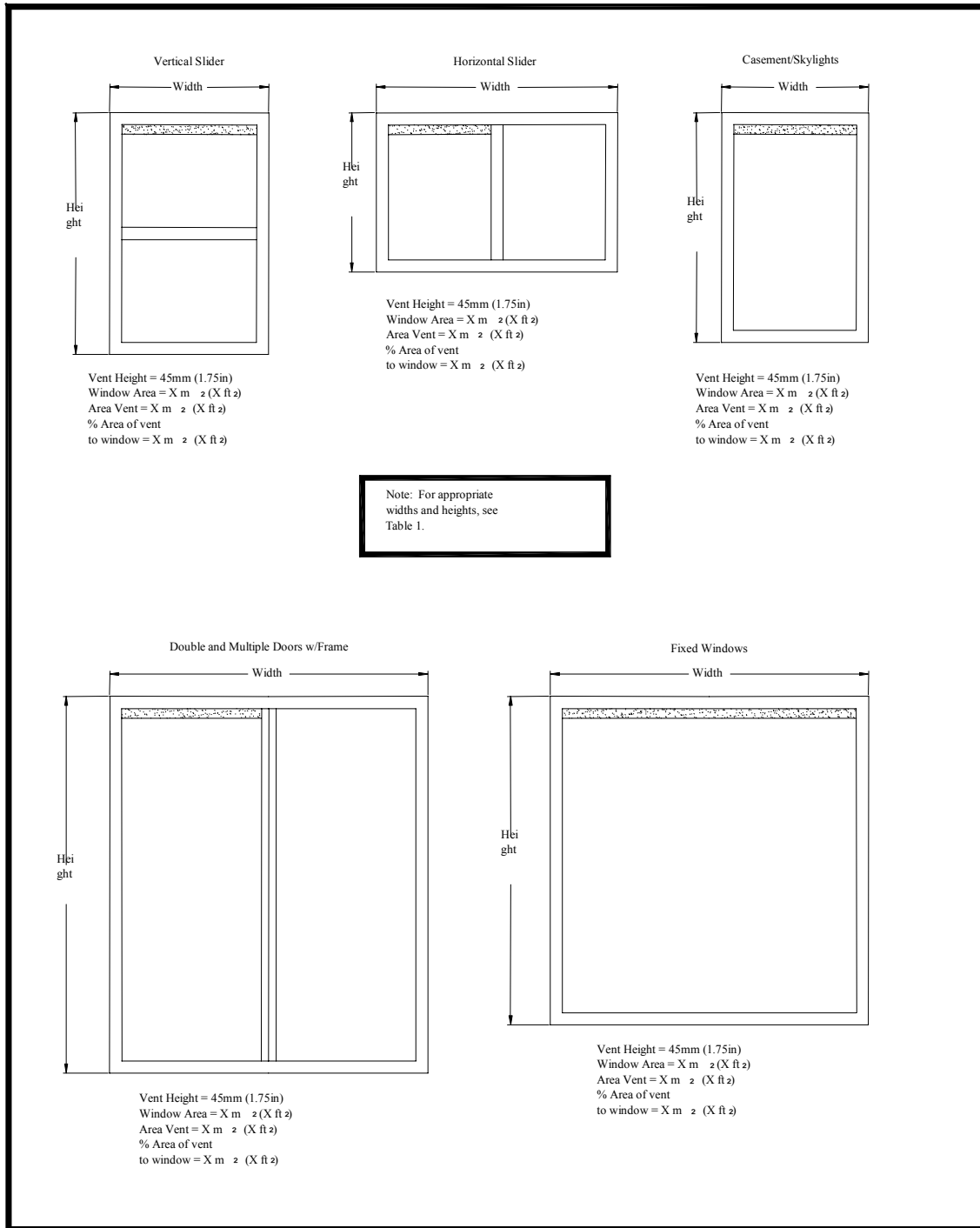

Figure 4-5 Integral Ventilators



The glazing area (daylighting) used in the calculations and sash members will vary by manufacturer. For appropriate widths and heights, see Table 4-1.

5 VARIATIONS FROM THE GENERAL REQUIREMENTS

This section presents and references methods for determining specific product system heat transfer properties or quantities used in the determination of these properties. At this time, the scope of these properties is limited to total product system U-Factor.

5.1 Windows and Sliding Glass Doors

5.1.1 Scope

This section presents additional details specific to windows and sliding glass doors.

This section presents and references methods for determining windows and sliding glass doors product system heat transfer properties or quantities used in the determination of these properties. The scope of these properties is limited to windows and sliding glass doors total product system U-Factor.

5.1.2 Variations from Standard Product Lines

This section presents additional product line details specific to windows and sliding glass doors.

Sash kits for any product type shall be rated using one of two options:

Option 1: Simulate and test (if required) in a default frame (see Figure 5-7) of similar material and design as the proposed installation.

Option 2: Sash kits that are identical in material and design as a manufacturer's rated product line may use the same ratings provided an NFRC-accredited simulation laboratory states that the frame qualifies as a default frame per Option 1.

5.1.3 Variations from Standard Individual Products

5.1.4 Variations from Standard Simulation and Test Conditions

5.1.5 Calculation of Total Product Rating

The total fenestration product U-Factor shall be calculated as per Section 4.6.3. Perform the following calculation to determine total product rating.

$$U_t = \frac{\left[\sum(U_f A_f) + \sum(U_d A_d) + \sum(U_e A_e) + \sum(U_{de} A_{de}) + \sum(U_c A_c) \right]}{A_{pf}}$$

Where

Equation 5-1

U_t	=	<i>total product U-Factor</i>
A_{pf}	=	<i>projected fenestration product area</i>
U_f	=	<i>frame U-Factor</i>
A_f	=	<i>frame area</i>
U_d	=	<i>divider U-Factor</i>
A_d	=	<i>divider area</i>
U_e	=	<i>edge-of-glazing U-Factor</i>
A_e	=	<i>edge-of-glazing area</i>
U_{de}	=	<i>edge-of-divider U-Factor</i>
A_{de}	=	<i>edge-of-divider area</i>
U_c	=	<i>center-of-glazing U-Factor</i>
A_c	=	<i>center-of-glazing area</i>
U_t	=	<i>total product U-Factor</i>

5.1.6 Figures

None.

5.2 Swinging Doors

5.2.1 Scope

This section presents additional details specific to side hinged exterior door system.

This section presents and references methods for determining specific side hinged exterior door system heat transfer properties or quantities used in the determination of these properties. At this time, the scope of these properties is limited to total door system U-Factor.

5.2.2 Variations from Standard Product Lines

A given series of entrance door systems defined by skin material, core material and edge-of-door construction that differ only in:

- A. Size.
- B. Panel and cut out configurations.
- C. The replacement of core and/or panel area with glazing system.
- D. Center-of-lite characteristics and edge-of-lite characteristics, such as glazing types, gap widths, glazing lite areas, use of dividers, use of spacers, glazing coatings, gas fills.
- E. Opening/non-opening configurations, e.g. X, O, XX, XO, OXXO etc.
- F. In-swing or out-swing operation.

- G. Door slab changes where one component of the same physical shape with a thermal conductivity that does not differ by more than a factor of 10.
- H. Frame components, e.g. headers, jambs and threshold; and
- I. Variations in frame and/or door interior/exterior finish, paint, varnish or stain do not constitute different product lines provided that each of these variations does not change the surface emittance by more than 0.10.

5.2.3 Variations from Standard Individual Products

Products with multiple sill options, where the sill design changes to accommodate different installation requirements, made of the same materials type shall be different individual products within the same product line.

5.2.4 Variations from Standard Simulation and Test Conditions

This section presents rules that may be used to reduce the number of simulations of individual products necessary to represent a product line. These rules may be used either with the product line validated simulation procedure (see Section 4.1.1) or with the testing alternative (see Section 4.1.2).

Each door of a double door or swinging patio unit shall be rated as the single door of the same style or model. For opaque doors with flat, raised or embossed panels, a 6-panel layout shall be representative of all panel doors within a product line of the same panel thickness. For non-wood doors only, this layout may also be considered representative of flush doors. See Figure 5-3 for a typical 6-panel layout.

For representative production line specimens, doors, sidelites and transoms of the complete system (slab, frame and sill) shall be within ± 25 mm (1 in.) of the appropriate model size listed in Table 4-3.

A manufacturer shall rate a door slab or slab sidelite using default frame components. The default frame components for door slab or slab sidelite testing shall be as follows: See Reference 2 for drawings.

- A. 115 mm (4.56 in.) softwood single rabbetted frame of 8 to 12 percent moisture content, with a specific gravity of 0.35 to 0.45, with a dual durometer plastic compression weatherstrip and flexible sweep. The default door sill shall be a standard combination wood/aluminum sill where the aluminum does not extend to the interior that performs as well or better than the default door sill illustrated in Figure 5-8 and Figure 5-9.
- B. Steel default frame shall consist of a 145 mm (5.75 in.) - 16 Ga. pressed painted steel frame with a minimum 120 mm (4.75 in.) throat depth, applied weather-strip and an aluminum non-thermally

broken sill with a sill wall thickness of 1.4 mm to 1.6 mm (0.055 in. to 0.065 in) and no substrate. Frame shall consist of a head jamb, hinge jamb, lock jamb, and necessary anchors and reinforcement for hinges and locks. See Figure 5-5 and Figure 5-6.

- C. Polypropylene door lite frame (See Reference 2 for composite).
- D. Default caming profile (See Reference 2).

If a manufacturer wishes to simulate a door slab in both the wood and steel default frames (or proprietary wood and steel frames), the manufacturer may either simulate all individual products in the matrix or develop an add-on for the steel frame. To develop the steel frame add-on, all the individual products in the matrix shall be simulated in the wood default frame. The best performing product in the wood frame shall then be simulated in the steel frame. The difference between these two U-Factors shall be the steel frame add-on. The U-Factor for the remaining products in the steel frame shall be the U-Factor for that product in the wood frame plus the steel frame add-on.

For composite doors, a manufacturer may also choose to simulate all glazing options in the default door lite frame to represent all their door lite frames.

For sill options with a higher U-Factor than the default sill, an add-on for the sill may be determined by simulating the best performing system with both sills and using the difference as a sill add-on.

5.2.5 Calculation of Total Product Rating

Total Fenestration Product U-factors for Model Sizes shall be calculated in accordance with Section 4.5.1.

To reduce the number of individual products necessary to represent a product line, refer to the guidelines prescribed in Section 4.2.4 and Section 5.2.4.

Products of the same style or model number within the same product line that differ from one another in size only shall be assumed to have the same U-factor as the model size listed in Table 4-3. Separate calculations or testing on these products shall not be required.

When simulating U-factors for continuous single pane decorative lites (decorative lites includes glass and caming), the decorative lite glass shall be assumed to have the same properties as clear glass of the same glass thickness and each decorative lite caming pattern shall be considered to be a different individual product or the optional caming pattern as shown in the Table 5-1 and Table 5-2 may be used to represent all decorative lite caming patterns. The default caming profile may be used to represent any caming profile.

When simulating U-factors where a single pane decorative lite (continuous or non-continuous) is used as the middle layer of a triple glazed glass unit, the decorative lite glass shall be assumed to have the same properties as clear glass of the same glass thickness and each decorative lite coming pattern shall be considered to be a different individual option or the optional coming pattern as shown in the Table 5-1 and Table 5-2 may be used to represent all decorative lite coming patterns. The default coming profile may be used to represent any coming profile.

5.2.5.1 Simplifications

For U-factor simulation, if the minimum distances between the surrounding glass and the decorative lite, both glass and coming, are greater than 3 mm (0.118 in.):

- A. the coming pattern may be ignored and the option modeled as triple-glazed, or
- B. the decorative lite layer may be ignored and the option modeled as double-glazed

For SHGC simulation, the double-glazed option shall be rated with the less than 25 mm (1 in.) divider option. For reporting purposes, this option shall not be grouped with any other option.

Products may be grouped based on glazing size. These groups shall be unglazed, 1/4, 1/2, 3/4 and full lite. Unglazed slabs shall be solid doors, either flush or panel doors. The glazing designations shall be defined as follows:

Table 5-1 Glazing and Divider Patterns for Doors

Individual Product	Flush Doors			Embossed, Stile and Rail Panel Doors	
	For Doors with	Simulated or Test as	Optional Caming Pattern ⁷	Glass inserts for a 6-panel door	Optional Caming Pattern ⁷
1/4 glazing	0.265 m ² (410 in. ²) or less	560 mm by 480 mm (22 in. by 19 in.)	5 vertical 3 horizontal	replace upper two panels and upper intermediate stile	< 610 mm (24 in.) use 5 vertical
1/2 glazing	0.265 m ² -0.581 m ² (410-900 in. ²)	560 mm by 1040 mm (22 in. by 41 in.)	5 vertical 8 horizontal	replace upper four panels, upper and center intermediate stiles and upper rail	610 mm (24 in.) use 6 vertical
3/4 glazing	0.581 m ² -0.710 m ² (900-1100 in. ²)	560 mm by 1270 mm (22 in. by 50 in.)	5 vertical 10 horizontal	replace lower four panels, center and lower intermediate stiles and lower rail	For horizontal Use the formula (H/4.5)-1
Full glazing	0.710 m ² (1100 in. ²) or more	560 mm by 1625 mm (22 in. by 64 in.)	5 vertical 13 horizontal	replace all panels and all intermediate stiles and rails	H=height

⁷ When adding caming to the glazing option in the patterns as designated, the center-of-lite becomes non-existent and the entire glazing becomes edge-of-lite that may be less than 63 mm (2.5 in.).

Table 5-2 Glazing and Divider Patterns for Sidelites

	Flush Doors			Embossed, Stile and Rail Panel Doors	
Individual Product	For Sidelites with	Simulated or Test as	Optional Caming Pattern ⁸	Glass inserts for a 3-panel sidelite	Optional Caming Pattern ⁸
1/4 glazing	<0.042 m ² (65 in ²)	200 mm by 200 mm (8 in. by 8 in.)	1 vertical 1 horizontal	replace upper panel	vertical 1
1/2 glazing	0.042 m ² -0.226 m ² (65 in ² to 350 in ²)	200 mm by 915 mm (8 in by 36 in)	1 vertical 8 horizontal	replace upper two panels and upper intermediate rail	610 mm (24 in.) use 6 vertical
3/4 glazing	0.226 m ² -0.297 m ² (350 in ² to 460 in ²)	200 mm by 1270 mm (8 in. by 50 in.)	1 vertical 10 horizontal	replace lower two panels and lower intermediate rail	For horizontal Use the formula ($H/4.5$)-1
Full glazing	> 0.297 m ² (> 460 in ²)	200 mm by 1625 mm (8 in. by 64 in.)	1 vertical 13 horizontal	replace all panels and all intermediate rails	H=height

⁸ When adding caming to the glazing option in the patterns as designated, the center-of-lite becomes non-existent and the entire glazing becomes edge-of-lite that may be less than 63 mm (2.5 in.).

5.2.6 Figures

Figure 5-1 Exterior Steel Composite Door System Area Schematic - Vertical Elevation

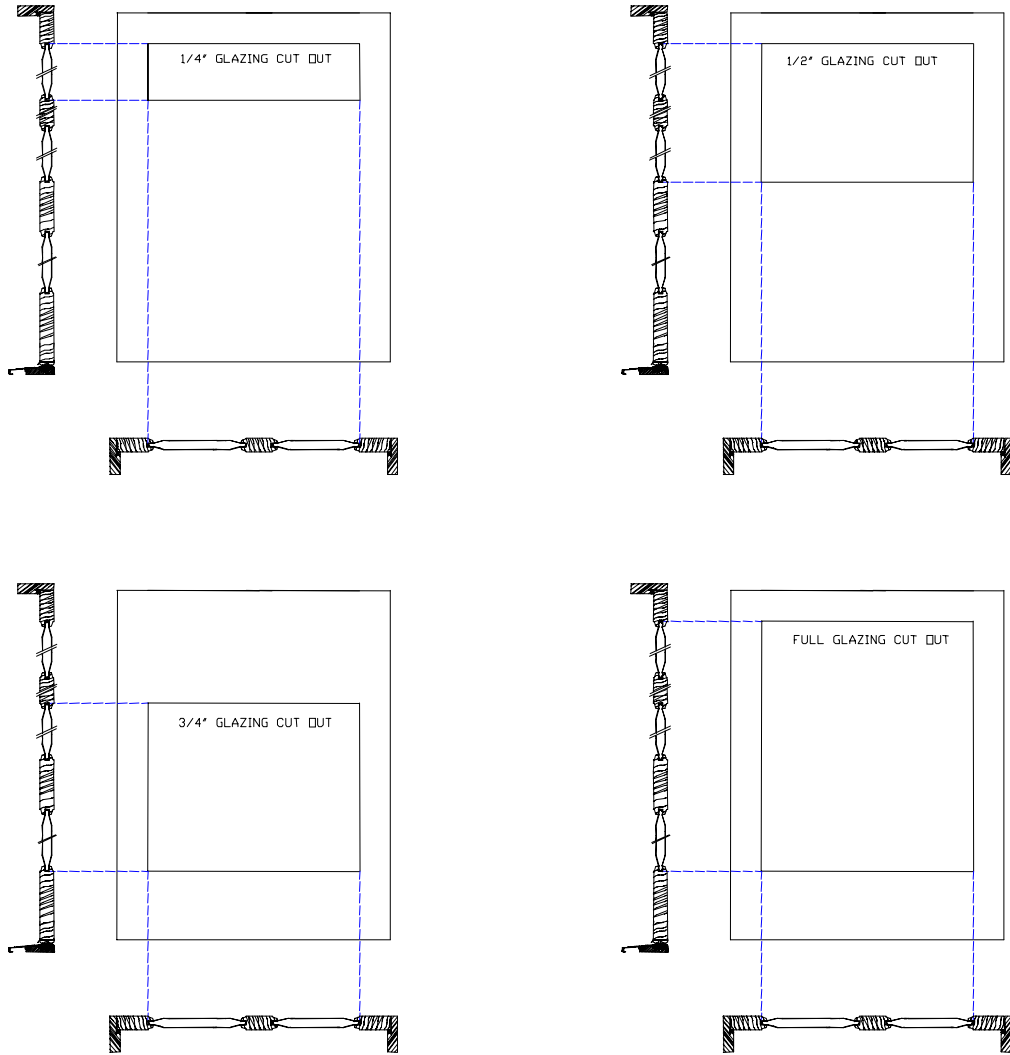
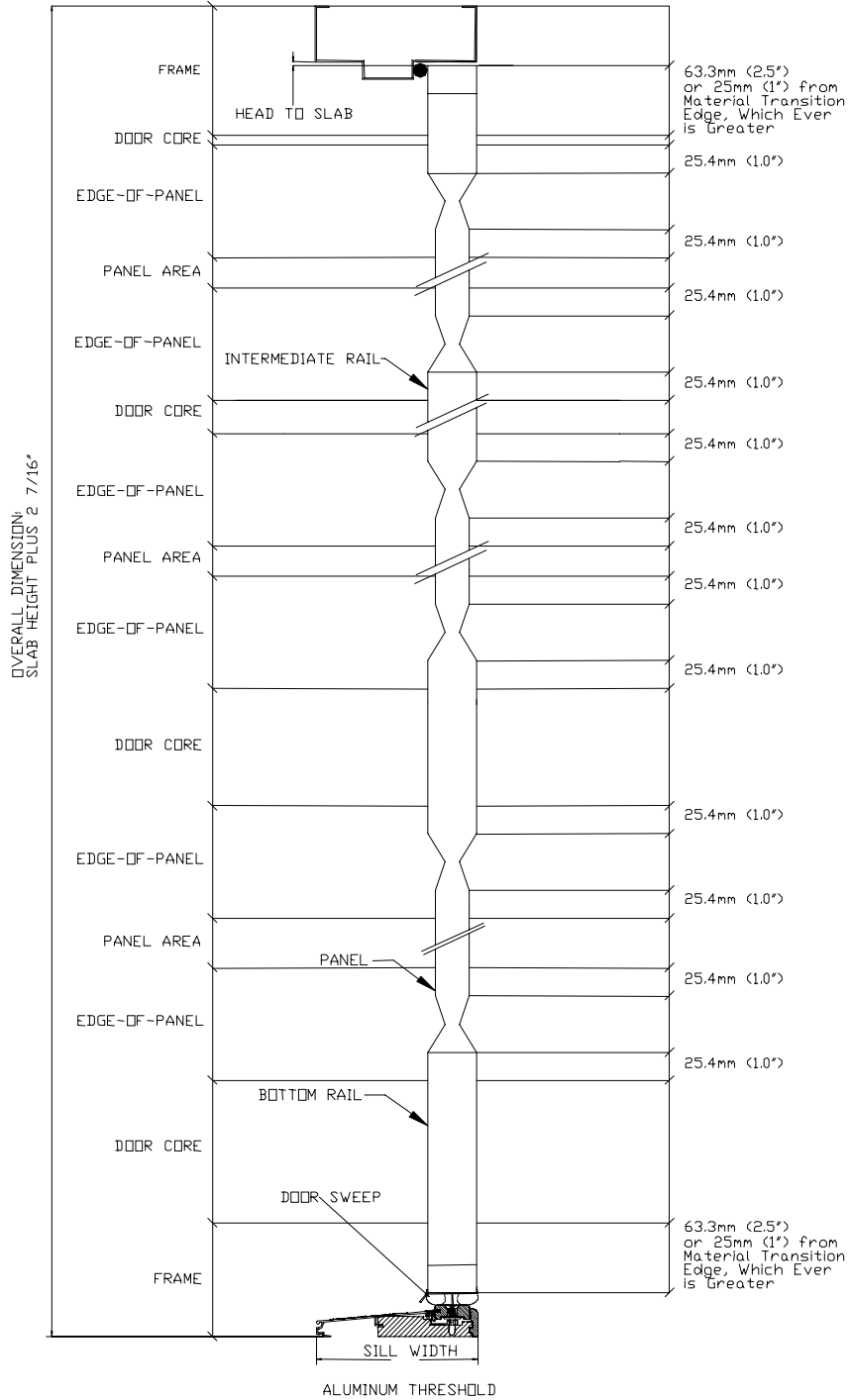

Figure 5-2a Exterior Steel/Composite Door System-Vertical Elevation in Steel Frame



The projected door area is the rough opening area less installation clearances. Sidelite area schematic may be identical or similar without perimeter weatherstrip and bottom sweep.

Figure 5-4 Typical 6-panel layout

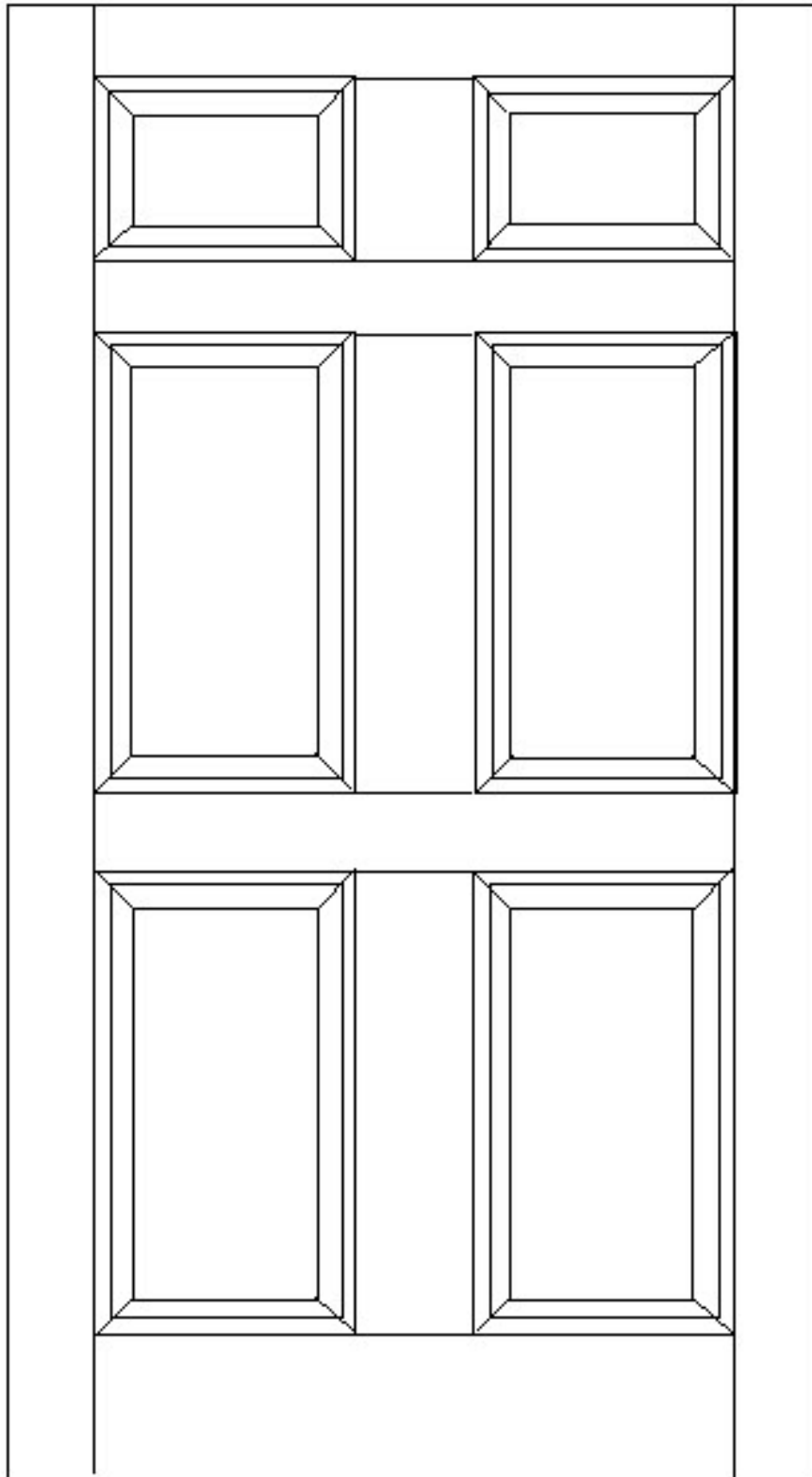

Figure 5-5 Common Pressed-Steel Frame - Single Unit Type Pressed-Steel Frame

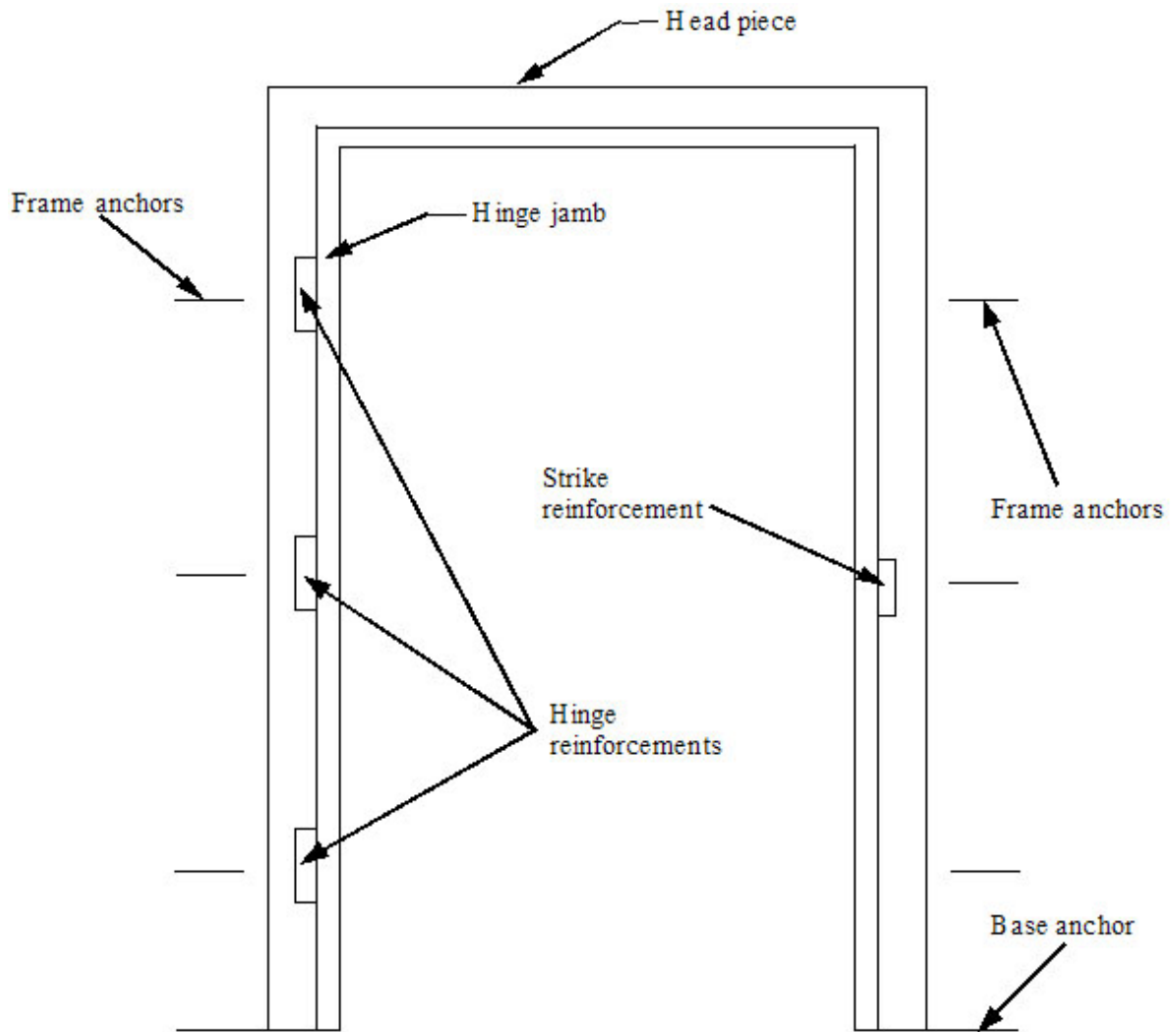
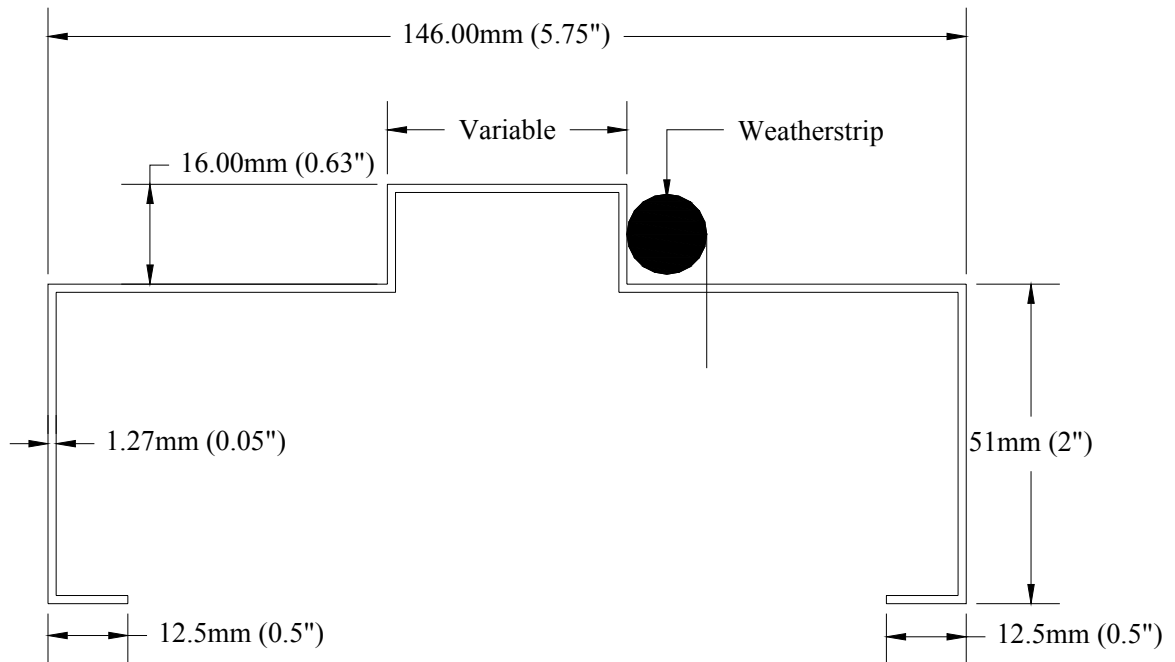

Figure 5-6 Frame Cross Section



Pressed Steel Frame Specification (16 G)

Pressed Steel Frame Specification

Single-unit type pressed steel frames shall consist of a head, a sill and two jamb pieces, hinge reinforcements, a strike plate reinforcement and base and wall anchors

The wall anchors provided shall be adjustable or fixed masonry anchors, bolts with expansion shells, channel clips, "Z" clips, wood stud anchors or steel anchors.

The head and jamb pieces shall be constructed, as shown in Figure 5-5.

Figure 5-7 Wood Default

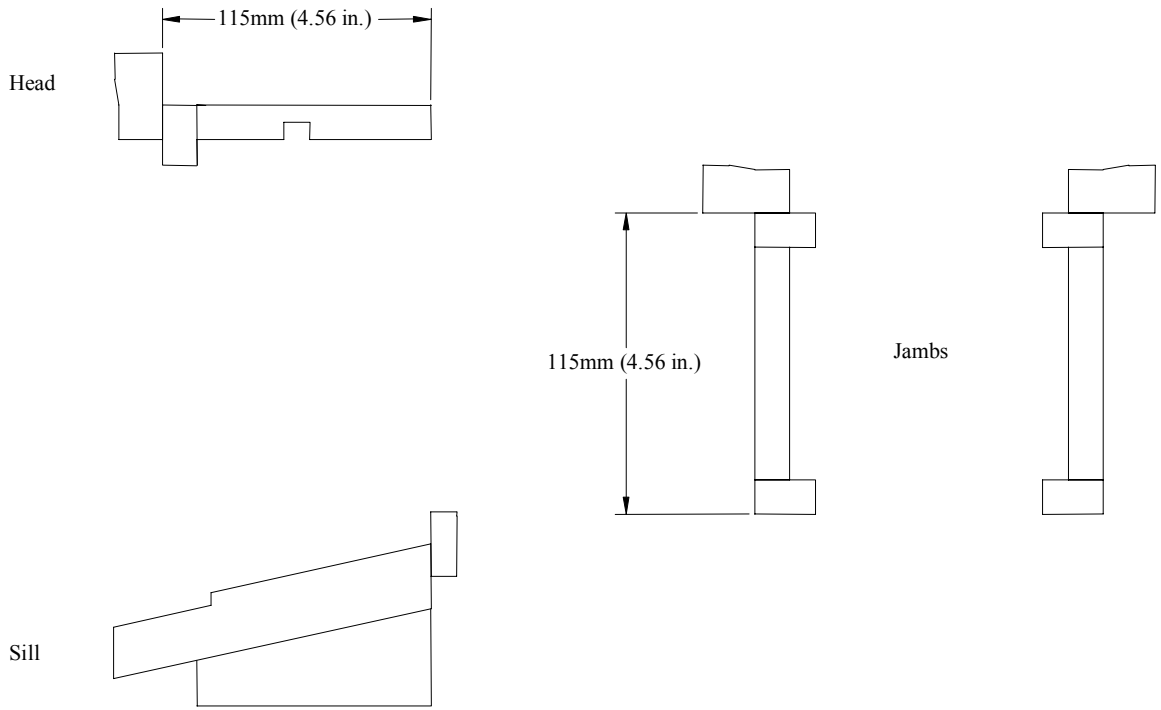

Figure 5-8 Default Wood Door Head Jamb and Side Jamb

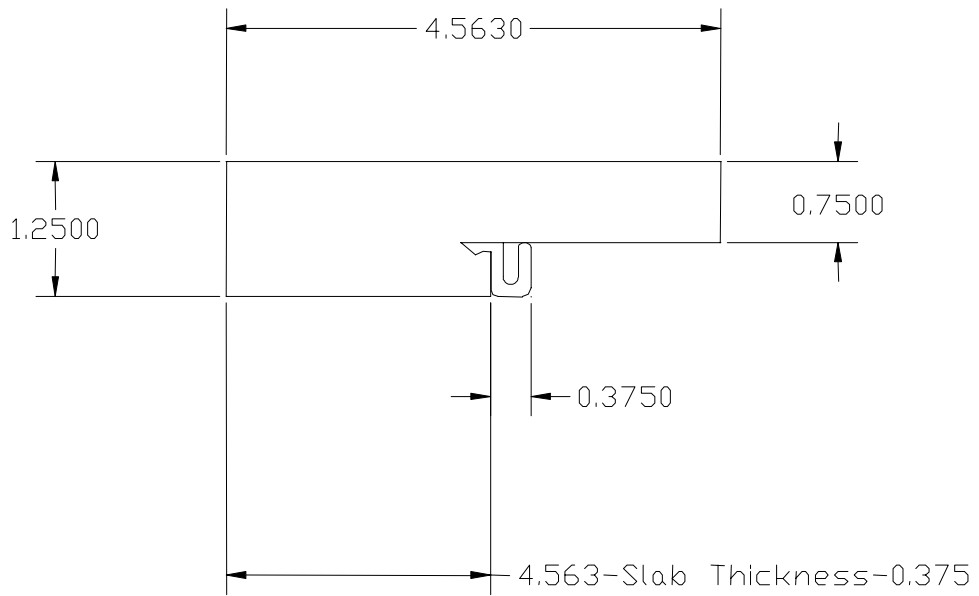
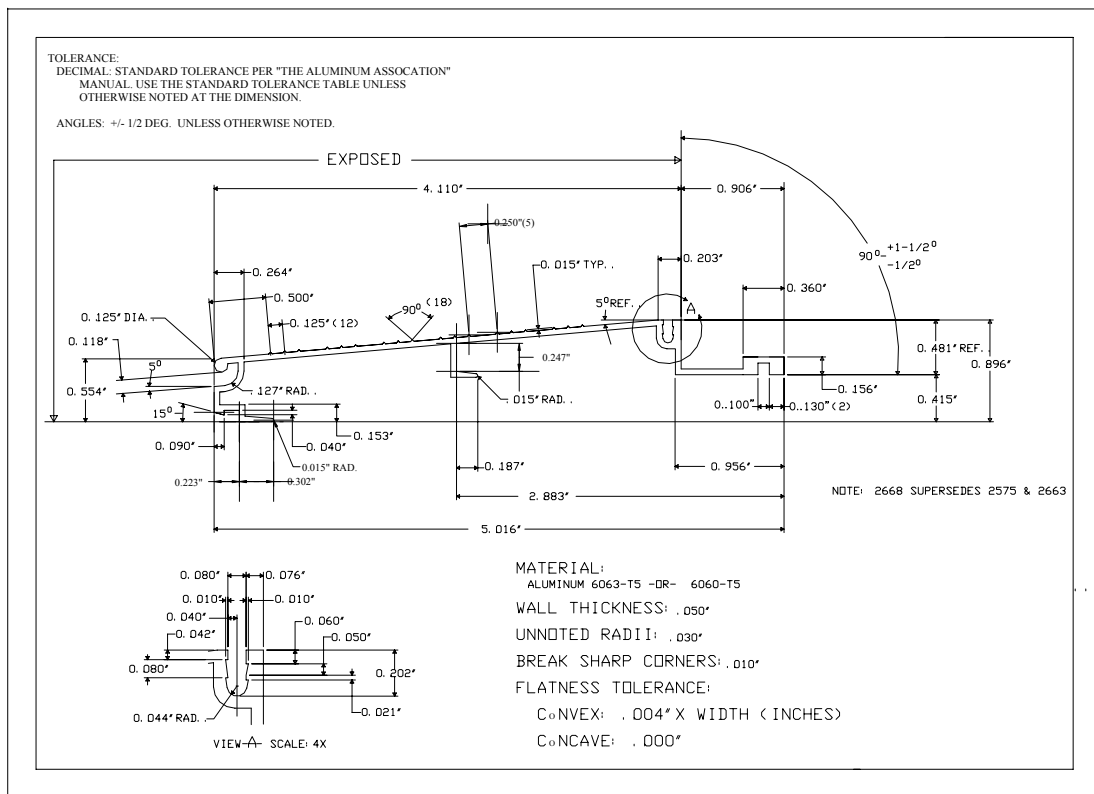
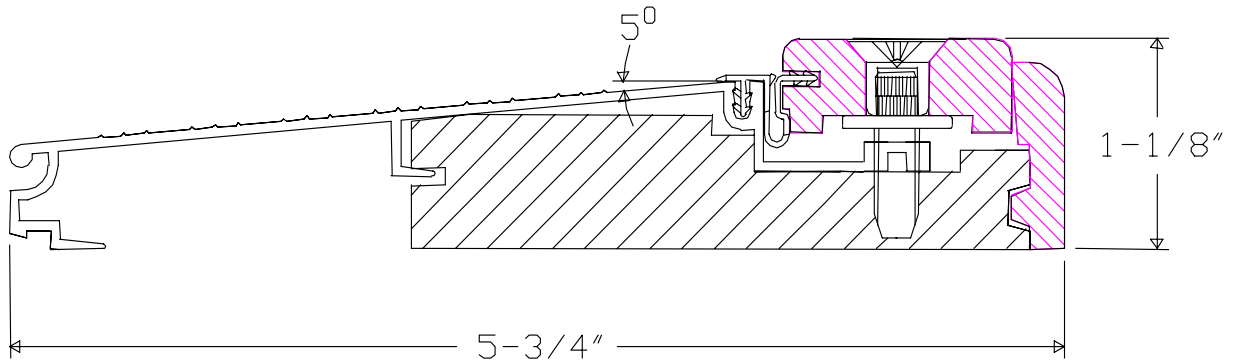

Figure 5-9 Default Door Sill



5.3 Skylights

5.3.1 Scope

This section presents additional details specific to skylights.

This section presents and references methods for determining specific skylight system heat transfer properties or quantities used in the determination of these properties. At this time, the scope of these properties is limited to total skylight system U-Factor. For additional simulation parameters see Reference 2.

5.3.2 Variations from Standard Product Lines

If a skylight can be installed using more than one of the installation methods listed below, the skylight product line shall include all the pertinent options as individual products. The method in which skylights are mounted will affect the U-Factor of the skylight.

Mounting variations include:

- A. Inset mount where the curb of the skylight extends into the rough opening in the roof; and
- B. Curb mount where the outside of the curb is equal to the rough opening in the roof; and
- C. Curb mount where the inside of the curb is equal to the rough opening in the roof.

Variations of each mounting type may occur.

5.3.3 Variations from Standard Individual Products

None

5.3.4 Variations from Standard Simulation and Test Conditions

Skylights and other sloped glazing products shall be simulated and rated at a slope of 20° above the horizontal. For determining validation of the baseline product only, skylights and other sloped glazing products, shall be simulated and tested in a vertical position. Ratings for test only products shall be converted to the 20° slope from the vertical position by multiplying the tested value at vertical by 1.20.

5.3.4.1 Curb

Curb mounted skylights that do not have an attached integral curb when manufactured shall be simulated and tested installed on a nominal "2 by 4" wood curb made from douglas fir, with no knots.

5.3.4.2 Size

The skylight sizes listed in Table 4-3 are based on the center of rafter to center of rafter dimension. The 1200 mm by 1200 mm (47 in. by 47 in.) size is representative of an 1180 mm by 1180 mm (46.5 in. by 46.5 in.) rough opening.

5.3.4.3 Skylight area

The U-Factor for all skylights is based on the projected fenestration product area of the rough opening, which is 1180 mm by 1180 mm (46.5 in. by 46.5 in.).

5.3.5 Calculation of Total Product Rating

The total fenestration product U-Factor shall be calculated as outlined below:

- A. Determine all of the following, as applicable:
 - i. Center-of-glazing U-Factor per the total product height procedure as defined in Reference 2 using an approved center-of-glazing simulation program, with input as needed from the approved glazing conductance test procedure given in Section 4.3.5.2.
 - ii. Edge-of-glazing U-Factor using an approved 2-D heat transfer simulation program; In the case that center-of-glass thermal performance is simulated, this center-of-glass configuration shall be inserted into the frame and the spacer assembly shall be added. In the case that that glazing component test procedure had to be utilized, the entire glazing system shall be represented as a homogeneous slab of material with conductivity equal to the average conductivity of the measured specimen. For mullions and meeting rails, two glazing systems shall be inserted on each end and the reported U-Factor shall be the average of the two edge-of-glass U-Factors.
 - iii. Divider U-Factor using an approved 2-D heat transfer simulation program. Divider shall be simulated with two glazing systems pointing in opposite directions, simulated in a vertical orientation.
 - iv. Edge-of-divider U-Factor using an approved 2-D heat transfer simulation program. Edge of divider U-Factor shall be the average of the two edge-of-glass section U-Factors.
 - v. Frame U-Factor using an approved 2-D heat transfer simulation program. Frame U-Factor is always calculated on the exposed indoor side of the frame, starting at the bottom of the frame and ending at the indoor sightline. For mullion and meeting rail cross-sections, frame surface is counted from one indoor sightline to another; and
 - vi. The component areas of:
 - (a) Center-of-glazing area.
 - (b) Divider area.
 - (c) Edge-of-glazing area.
 - (d) Edge-of-divider area.

- (e) Frame area.
 - (f) Projected fenestration product area.
- B. Perform the following calculations as shown in Equation 5-2:
- i. The U-Factor shall be reported to 0.05 W/m²K (0.01 Btu/h·ft²·°F).
 - ii. Multiply the center-of-glazing, edge-of-glazing, divider, edge-of-divider and frame U-Factors by their corresponding areas.
 - iii. Total these five quantities.
 - iv. Divide this total by the projected fenestration product area to produce simulated total fenestration product U-Factors for all the fenestration products in the matrix of required U-Factors (see Section 4.5.1).

$$U_t = \frac{[\sum(U_f A_f) + \sum(U_d A_d) + \sum(U_e A_e) + \sum(U_{de} A_{de}) + \sum(U_c A_c)]}{A_{pt}} \quad \text{Equation 5-2}$$

Where

- U_t = total product U-Factor
- A_{pt} = projected fenestration product area
- U_f = frame U-Factor
- A_f = frame Area
- U_d = divider U-Factor
- A_d = divider area
- U_e = edge-of-glazing U-Factor
- A_e = edge-of-glazing area
- U_{de} = edge-of-divider U-Factor
- A_{de} = edge-of-divider area
- U_c = center-of-glazing U-Factor
- A_c = center-of-glazing area

5.3.6 Figures

None.

5.4 Tubular Daylighting Devices

5.4.1 Scope

This section presents and references methods for determining specific tubular daylighting device system heat transfer properties or quantities used in the determination of these properties. For additional simulation

parameters see Reference 2. At this time the only ratings available for these products are based on computer simulations. When NFRC can determine an appropriate test procedure a Technical Interpretation will be issued. Simulations shall be performed per Reference 13 using standard model conditions stated in Section 5.4.4.4.

5.4.2 Variations from Standard Product Lines

A tubular daylighting device product line shall only consist of individual products of the same tube material, exterior dome material and interior diffuser material.

5.4.3 Variations from Standard Individual Products

None

5.4.4 Variations from Standard Simulation and Test Conditions

5.4.4.1 Orientation

U-Factors for tubular daylighting devices shall be rated, with the tube in a vertical orientation (see Figure 5-10). The diffuser is simulated attached to the ceiling, the tubular section located in the attic space connecting the interior diffuser to the exterior dome and the exterior dome mounted to the roof deck. Therefore the heat flow shall be in the vertical direction. Standardized rating conditions are defined in Section 5.4.4.4.

5.4.4.2 Sizes

The tubular daylighting device size listed in Table 4-3 is based on a standardized 350 mm (14 in.) diameter tube opening.

5.4.4.3 Tubular Daylighting Device area

The U-Factor for all tubular daylighting devices is based on the tube diameter and the corresponding area associated with that diameter, which is 0.1 m^2 (1 ft^2). This area shall be used when calculating the total product U-Factor.

5.4.4.4 Standard Modeling Conditions

- A. 750 mm (30 in.) shift length (interior ceiling line to exterior roof line).
- B. 350 mm (14 in.) diameter shift opening.
- C. Convective correlation in the shift air cavity per Reference 13.

- D. Ceiling insulation shall be simulated as per Reference 13, [250 mm (10 in.) total depth], which is represented as an adiabatic boundary.
- E. An exterior 13 mm (0.5 in.) thick plywood roof deck.
- F. ASHRAE attic space boundary conditions on the exposed surface of the vertical shift material, from the top of the insulation material to the underside of the 13 mm (0.5 in.) plywood roof deck, modeled according to the procedures in Reference 13.
- G. Exterior boundary conditions applied to the exposed surface of the dome.
- H. Bottom of the tubular skylight covered with a light diffusing plate (manufacturer specific).

5.4.4.5 Calculation of Total Product Rating

The total tubular daylighting device system U-Factor shall be calculated as outlined below:

- A. Use the tubular shift area.
- B. Perform the following calculations as shown in Equation 5-3:
 - i. Calculate the total heat flow through the diffuser area exposed to the indoor environment, Q_d .
 - ii. Divide this total heat flow by the projected total tubular daylighting device interior opening area to produce computed total product U-Factor.

$$U_t = \frac{Q_d}{A_{pt}} \quad \text{Equation 5-3}$$

Where

- U_t = total tubular daylighting system U-Factor
- Q_d = total heat flow through the diffuser area exposed to the indoor environment
- A_{pt} = projected total tubular daylighting device shift interior opening area

5.4.5 Figures

Figure 5-10 Tubular Daylighting Device Product Schematic: Vertical Elevation

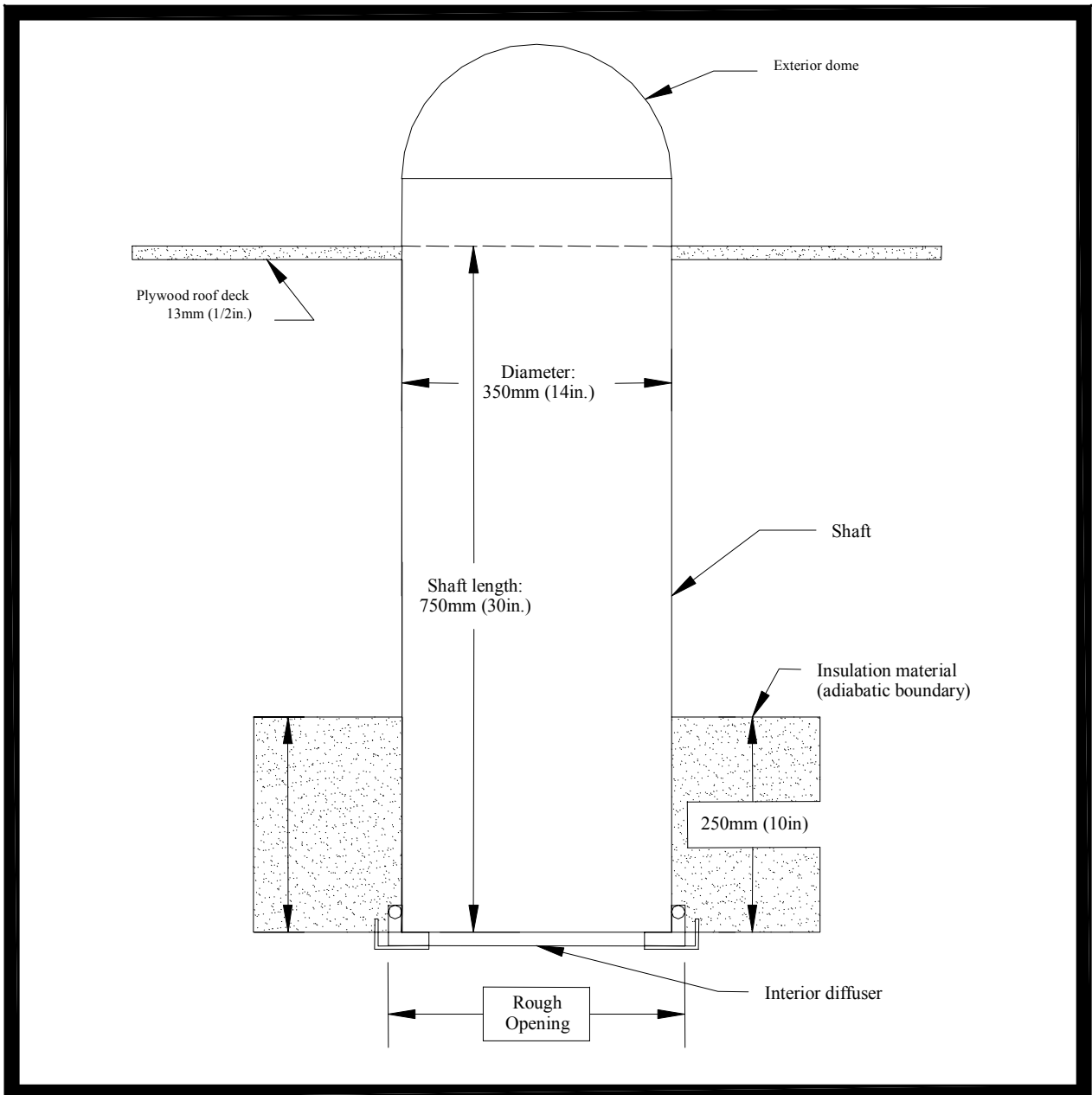

See Reference 13 for a more detailed drawing of the rough opening and diffuser plate attachment.

5.5 Garage (Vehicular Access) Doors

5.5.1 Scope

This section presents and references methods for determining specific residential garage door system heat transfer properties or quantities

used in the determination of these properties. At this time, the scope of these properties is limited to total garage door system U-Factor. For additional simulation parameters, see Reference 2.

5.5.2 Variations from Standard Product Lines

A given series of garage door systems defined by skin material, core material and edge of garage door construction that differ only in:

- A. Size.
- B. Solid panel and panel cut-out configurations.
- C. The replacement of core and/or panel area with glazing system.
- D. Center-of-lite characteristics and edge-of-lite characteristics, such as glazing types, gap widths, glazing lite areas, use of dividers, use of spacers, glazing coatings, gas fills.
- E. Panel/slab changes where one component of the same physical shape with a thermal conductivity that does not differ by more than a factor of 10.
- F. Jamb track or hardware components.
- G. Variations in panel/slat interior/exterior finish, paint, varnish or stain do not constitute different product lines provided that each of these variations do not change the surface emittance by more than 0.10, and
- H. Variations in end stile design, top edge and bottom edge panel designs.

5.5.3 Variations from Standard Individual Products

An individual product, in a product line, shall be, those products that comply with the requirements per Section 5.5.2.

5.5.4 Variations from Standard Simulation and Test Conditions

- A. Garage doors that consist of panels shall have the U-Factor determined using four (4) panels, each being 600 mm (24 in.) in height, with the following designation: Panel # 1 shall be the bottom most panel and panel #4 shall be the uppermost panel. The bottom panel, top panel and one intermediate panel shall be modeled.
- B. For garage doors that are of the 'roll-up' type, the slat height shall be 50 mm (2 in.) and shall have 48 slats for the determination of the U-Factor. The bottom panel, the top panel and the intermediate panels shall be modeled per manufacturer drawings.

- C. The bottom and top rails shall be identical for each individual product in a product line.
- D. For four panel doors with glazing options, the glazing shall be per the manufacturer's design. No dividers shall be considered for modeling purposes.

5.5.5 Total Product Rating

The total garage door system U-Factor shall be calculated as outlined below:

- A. Determine all of the following, as applicable:
 - i. Panel(s) U-Factor using the approved 2-D heat transfer computational program.
 - ii. Door core U-Factor using the approved 2-D heat transfer computational program.
 - iii. Center-of-glazing U-Factor per the total product height procedure as defined in Reference 2 using the approved center-of-lite computational program, with input as needed from the approved center-of-lite conductance test procedure given in Section 4.5.3.
 - iv. Edge-of-glazing U-Factor using the approved 2-D heat transfer computational program.
 - v. Lite frame U-Factor using the approved 2-D heat transfer computational program.
 - vi. Edge-of-panel U-Factor using the approved 2-D computational program.
 - vii. Stile U-Factor using the approved 2-D computational program; and
 - viii. The component areas in square feet, to the nearest 0.001 m^2 (0.010 ft^2) of:
 - (a) Lite frame area
 - (b) Edge-of-glazing area
 - (c) Center-of-glazing area
 - (d) Door core area
 - (e) Panel area
 - (f) Edge-of-panel area (top and bottom)
 - (g) Stile area (ends)
 - (h) Projected total exterior door system area
- B. Perform the following calculations as shown in Equation 5-4:

- i. Multiply the center-of-glazing, edge-of-glazing, panel, door core, lite frame, edge-of-panel and stile U-Factors by their corresponding areas.
- ii. Total these seven quantities; and
- iii. Divide this total by the projected total exterior garage door system area to produce computed total garage door system product U-Factors for all the door systems in the matrix of required U-Factors.

$$U_t = \frac{[(U_{lf}A_{lf}) + (U_eA_e) + (U_cA_c) + (U_{dc}A_{dc}) + (U_pA_p) + (U_{ep}A_{ep}) + (U_{es}A_{es})]}{A_{pt}}$$

Equation 5-4

Where

- U_t = total door system U-Factor
- U_{lf} = lite frame U-Factor
- A_{lf} = lite frame area
- U_e = edge-of-glazing U-Factor
- A_e = edge-of-glazing area
- U_c = center-of-glazing U-Factor
- A_c = center-of-glazing area
- U_{dc} = door core U-Factor
- A_{dc} = door core area
- U_p = panel U-Factor
- A_p = panel area
- U_{ep} = edge-of-panel U-Factor
- A_{ep} = edge-of-panel area
- U_{es} = end stile U-Factor
- A_{es} = end stile area
- A_{pt} = projected total door system area

5.5.6 Figures

Figure 5-11 Garage Door 2: Vertical Elevation, Glazing Area



Figure 5-12 Garage Door Product Schematic-Vertical Elevation

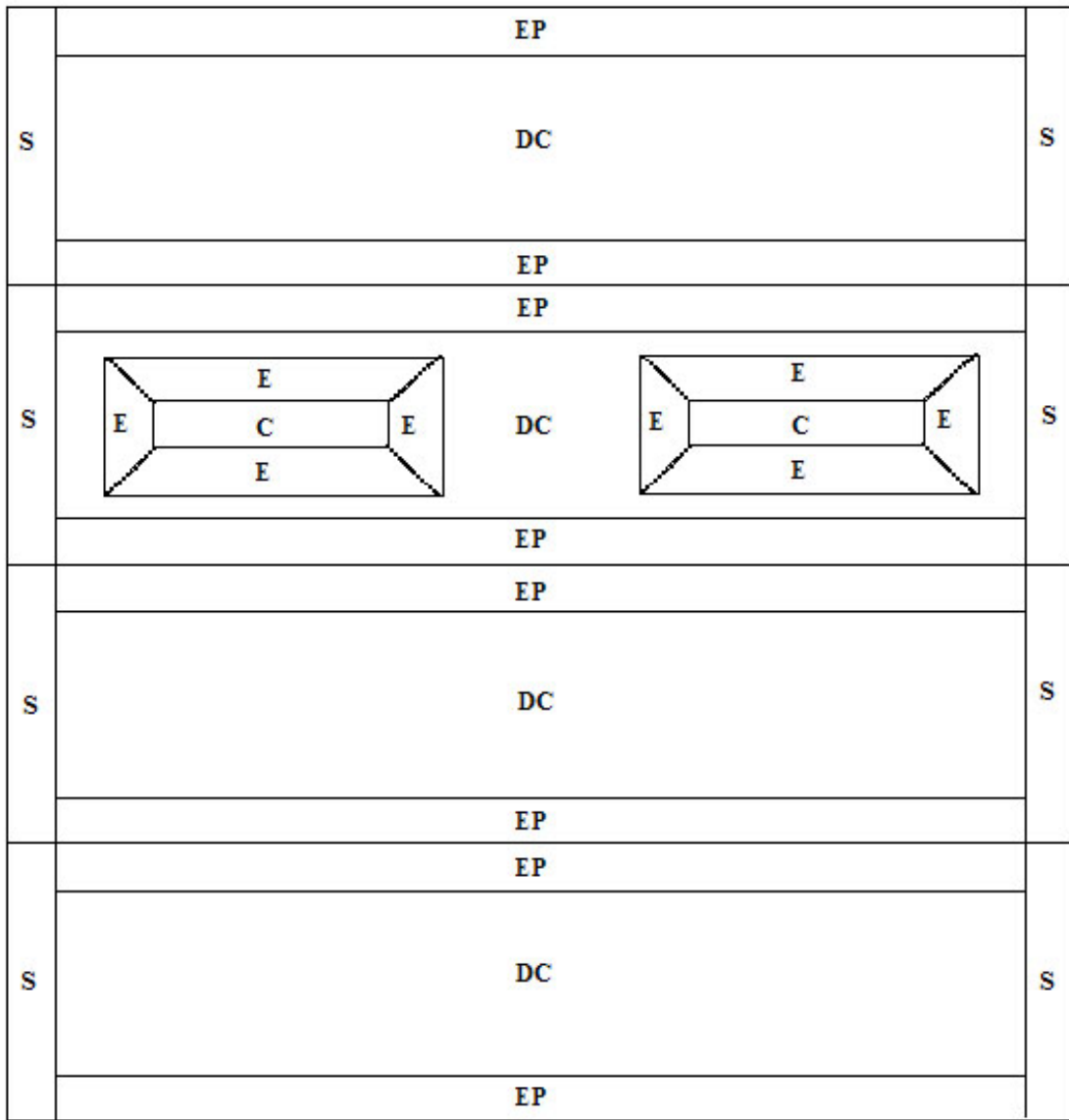

Legend

- S Stile
- DC Door Core
- EP Edge-of-Panel
- E Edge-of-Glazing (only if glazing is used; number of lites may vary)
- C Center-of-Glazing (only if glazing is used; number of lites may vary)

Not to Scale

Figure 5-13 Garage Door Horizontal Jamb Schematic (Exterior)

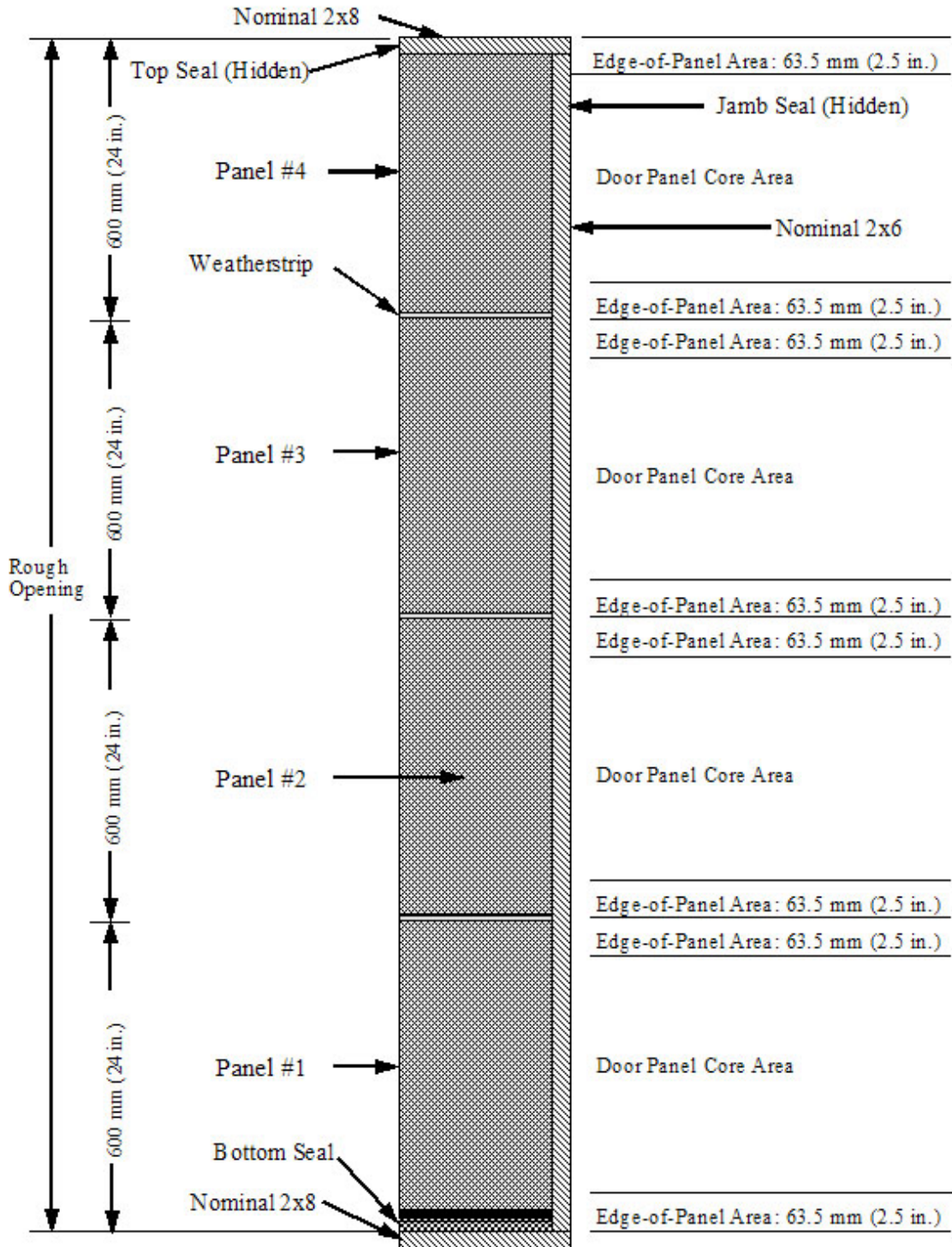

5.6 Non-Residential Products

5.6.1 Scope

Non-Residential fenestration systems covered by this method include products that are designed to be field glazed or field assembled units comprised of specified framing and glazing components, including, but not limited to:

5.6.1.1 Products Covered

Transparent and translucent wall systems where the glazing material is glass, plastic or other light transmitting panels (including opaque spandrel panels within the system), except those products where no testing or calculation procedure exists.

- A. Glazed wall support and framing systems.
- B. Products of any size and design.
- C. Products with single or multiple glazing layers.
- D. Products with spacer systems between glazings.
- E. Horizontal, vertical and sloped systems.
- F. Products that, by design, may have multiple framing components and/or glazing combinations.
- G. Fenestration systems using unitized construction, where a system is field assembled from factory assembled sub-units.
- H. Dynamic Glazing Products

5.6.1.2 Systems not covered

Include totally opaque walls and pre-assembled or pre-glazed fenestration products (See Table 4-3).

5.6.2 Variations from Standard Product Lines

None

5.6.3 Variations from Standard Individual Products

None

5.6.4 Variations from Standard Simulation and Test Conditions

5.6.4.1 Unspecified Product Sample Validation Criteria

If the product to be used for validation purposes is not specified, then the individual product used for validation purposes shall be simulated and tested using the following

criteria: The test specimen shall be constructed in such a manner as to be identical to the individual product simulated and have outside dimensions measuring 2000 mm by 2000 mm (79 in. by 79 in.), having one vertical mullion and two glazed lites. The glazing system configuration for the validation testing shall be nominal 25 mm (1 in.) outside dimension insulating glass utilizing two lites of 6 mm (1/4 in.) clear (uncoated glass), a typical dual-sealed aluminum spacer system and air-filled. There shall be no insulation of any type applied to the test specimen during validation testing. Validation will be achieved per Section 4.7.1

This section is to be used only in those instances where the representative sample for validation purposes has not been prescribed by a specifying authority, such as an architect, project manager, engineering firm, building owner, etc.

For simulating and testing all other fenestration operator types other than glazed wall systems, sloped glazing and solarium/sunroom systems, model sizes shall be consistent with the sizes listed in Table 4-3 of this standard.

5.6.4.2 Determining the thermal transmittance for solarium/sunroom systems

[*Note 6.:* This procedure is to be used when the solarium is glazed on-site. If manufactured window or door systems are used to create the glazed walls in a solarium, the thermal transmittance shall be determined in accordance with Part 1 of this standard.]

- A. The thermal transmittance of solarium/sunroom systems shall be determined in accordance with Section 4.1 of this standard.
- B. For simulating and testing site-built vertical glazed wall sections of solarium/sunroom systems, each Product Line shall have one baseline product be validated in accordance with Section 4.1.1 and 4.3.4, with the following exception: The individual product used for validation purposes shall be simulated and tested using the following criteria: The test specimen shall be constructed in such a manner as to be identical to the individual product simulated and have outside dimensions measuring 2000 mm by 2000 mm (79 in. by 79 in.), having one vertical mullion and two glazed lites. The glazing system configuration for the validation testing shall be nominal 25 mm (1 in.) outside dimension insulating glass utilizing two lites of

3 mm (1/8 in.) clear (uncoated glass), a typical dual-sealed aluminum spacer system and air-filled. There shall be no insulation of any type applied to the test specimen during validation testing. Validation will be achieved per Section 4.1.1.

- C. Sloped glazing systems shall be rated in accordance with Section 4.1 utilizing sample construction as described in Section 5.6.4.2.B.
- D. For simulating and testing all other fenestration operator types other than glazed wall systems and sloped glazing systems, model sizes shall be consistent with the sizes listed in Table 4-3 of this standard with glazing in accordance with Section 5.6.4.2.B.

5.6.5 Calculation of Total Product Rating

5.6.6 Figures

None.

6 REFERENCES

- [1] National Fenestration Rating Council. NFRC 102: Procedure for Measuring the Steady-State Thermal Transmittance of Fenestration Systems. Silver Spring, MD.
- [2] National Fenestration Rating Council. NFRC Simulation Manual. Silver Spring, MD.
- [3] American Society for Testing and Materials. C 177-97: Standard Test Method for Steady-State Heat Flux Measurements and Thermal Transmission Properties by Means of the Guarded-Hot-Plate Apparatus. Annual Book of Standards. Philadelphia, PA.
- [4] American Society for Testing and Materials. C 518-98: Standard Test Method for Steady-State Thermal Transmission Properties by Means of the Heat Flow Meter Apparatus. Annual Book of Standards. Philadelphia, PA.
- [5] National Fenestration Rating Council. List of Approved Simulation Programs. Silver Spring, MD.
- [6] American Society for Testing and Materials. C 1363-97: Standard Test Method for the Thermal Performance of Building Assemblies by Means of a Hot Box Apparatus. Annual Book of Standards. Philadelphia, PA.
- [7] American Society for Testing and Materials. E 1530-99: Standard Test Method for Evaluation the Resistance to Thermal Transmission of Thin Specimens of Materials by the Guarded Heat Flow Meter Technique. Annual Book of Standards. Philadelphia, PA.

- [8] IEEE-ASTM-SI-10 (2001): Standard for use of the International System of Units (SI): The Modern Metric System. (Replaces ASTM E 380).
- [9] American Society for Testing and Materials. C 1036-91 (Re-approved 1997) Standard Specification for Flat Glass, Annual Book of Standards, Philadelphia, PA.
- [10] American Society for Testing and Materials. C 1114-98 Standard Test Method for Steady State Thermal Transmission Properties by Means of the Thin-Heater Apparatus, Annual Book of Standards. Philadelphia, PA.
- [11] 2001 ASHRAE Handbook of Fundamentals, Atlanta, GA.
- [12] ANSI/DASMA 105-98
- [13] Proposed Methodology for Modeling Tubular Skylights (Daylighting Devices) for NFRC Rating Purposes, University of Massachusetts Technical Report, June 27, 2001.
- [14] ISO/FDIS 15099 (2001) – Thermal Performance of Windows, Doors and Shading Devices - Detailed Calculations

APPENDIX A (NON-MANDATORY INFORMATION)

A.1 Determination of Project Specific U-Factors

The system U-Factor ratings for project specific U-Factors shall be determined by an NFRC-accredited simulation laboratory, using NFRC-approved software tools which utilizes components of the NFRC-certified system, specifically with the frame, edge-of-glazing and center-of-glazing U-Factors. Each component of the total system shall be assigned percentages of the total product and the total system U-Factor shall be calculated using the procedures outlined in Section 4.6.3.

[**Note 7.:** Reference the contents of Section 5.6 of this document.]

A.2 Determination of U-Factors at Non-Standard Sizes

A U-Factor-rating matrix that is size specific may be developed in accordance with NFRC 100 procedures and requirements. A matrix shall only be developed for those product lines and individual products of a product line, that have been submitted to an NFRC-licensed independent certification and inspection agency (IA) for certification authorization purposes at the product size as defined in Table 4-3. Products that have previously received certification authorization may also have a matrix developed. Each matrix shall be specific to an individual product within a product line.

The matrix shall include the standard rating size and sizes that are defined by the manufacturer.

The fenestration thermal performance parameter ratings (i.e.: U-Factor,) shall be determined by an NFRC-accredited simulation laboratory, using NFRC-approved software tools, which utilizes components of the NFRC-certified system, specifically with the frame, edge-of-glazing and center-of-glazing thermal performance ratings, where applicable. Each component of the total system shall be assigned percentages of the total product and the total system thermal performance parameter shall be calculated using the procedures outlined in Section 4.6.3.

[**Note 8.:** Until such time that a certification change is made in the NFRC Product Certification Program, the thermal performance parameters that are determined at sizes other than the product size in Table 4-4 are for informational purposes only.]

Table 6-1 Example U-Factor Size Matrix

Example Only - Widths, Heights and U-Factors

		Width								
		36	48	60	72	80	84	96	108	120
H e i g h t	36	0.55	0.52	0.49	0.48	0.47	0.47	0.46	0.45	0.45
	48	0.53	0.49	0.47	0.46	0.45	0.44	0.44	0.43	0.42
	60	0.52	0.48	0.46	0.44	0.43	0.43	0.42	0.41	0.41
	72	0.51	0.47	0.45	0.43	0.42	0.42	0.41	0.40	0.40
	80	0.51	0.47	0.44	0.43	0.42	0.41	0.41	0.40	0.39
	84	0.51	0.47	0.44	0.42	0.42	0.41	0.40	0.40	0.39
	96	0.50	0.46	0.44	0.42	0.41	0.41	0.40	0.39	0.38
	108	0.50	0.46	0.43	0.42	0.41	0.40	0.39	0.39	0.38
	120	0.50	0.46	0.43	0.41	0.40	0.40	0.39	0.38	0.38

Shaded area indicates NFRC 100 Standard Size for Certification and Rating Purposes.

The values stated, other than the identified standard size, in the matrix above, are for informational purposes only and have not been authorize for certification. The standard size rating is also shown on the label certificate, to which this matrix is attached. For additional information, contact the IA stated on the label certificate.

INDEX

15099 Section 4.1.3.....	10	curtain walls.....	7, 23
2-D heat transfer program.....	25	custom product.....	11
6-panel layout.....	5, 36	decorative panel.....	4
air.....	1, 6, 8, 22, 24	Default frame for door slab testing.....	36
alternative test procedure.....	10	divider ...	2, 3, 4, 5, 7, 8, 9, 27, 29, 30, 35, 52
aluminum.....	1, 4, 36	divider area.....	2, 27, 35, 51
aluminum.....	4	dividers.....	5, 22, 24, 35, 56, 57
aluminum spacer.....	64	door.....	4
aluminum spacer.....	63	leaf.....	2, 4, 5
appropriate model size.....	36	wood.....	4
argon.....	1	Door leaf.....	4
ASTM C 1036-02.....	18	door bottom sweep.....	2, 5
average conductivity.....	25, 26	door core.....	2, 3, 5, 8, 58
base profile.....	3	door core area.....	2, 57, 58
baseline product.....	3	door core U-Factor.....	58
basement window.....	3	door core U-Factor.....	8
bay window.....	3	door jambs.....	2
bolts.....	24	Door/slab.....	5
bow window.....	3	doors.....	2, 4, 5, 6, 7, 26, 34, 36, 37, 56, 57
C 1036.....	65	double door.....	36
C 1363.....	64	double hung.....	9
C 177.....	64	dual action window.....	5
C 518.....	64	Dynamic Glazing Product.....	5, 11
caming.....	3	E 1530.....	64
Caming.....	39, 40	edge-of-divider ...	2, 3, 5, 8, 9, 22, 27, 29, 30, 52
casement.....	3, 23	edge-of-divider area.....	51
center-of-glazing ..	2, 3, 5, 8, 9, 22, 25, 26, 27, 51, 52, 58, 66	Edge-of-divider area.....	2
center-of-glazing area ...	2, 27, 35, 51, 52, 57, 58	edge-of-divider U-Factor.....	8
center-of-glazing U-Factor.....	8, 58	edge-of-frame.....	2
cladding.....	3	edge-of-glazing	2, 3, 5, 8, 9, 21, 22, 27, 29, 30, 52, 58, 66
clear glass.....	1	edge-of-glazing area..	2, 27, 35, 51, 52, 57, 58
combination assembly.....	4	edge-of-glazing U-Factor.....	8, 58
combination mullion.....	6	edge-of-panel.....	2, 5, 9, 58
commercial doors.....	9	edge-of-panel area.....	2, 57, 58
Component substitutions.....	22	edge-of-panel U-Factor.....	9, 58
composite assembly.....	4	embossed/raised panel.....	5
core material.....	1, 35, 56	end stile area.....	58
Curb mounted skylight.....	50		
curtain wall.....	4		

end stile U-Factor.....	9, 58	Section 7.....	20
exterior door system.....	5	Section 8.2.....	20
factory assembled.....	24	Section 8.3.....	20, 21
fiberglass.....	1, 4	Section 8.4.2.1.....	20
fixed panel.....	5	krypton.....	1
flush doors.....	4, 36	latch jamb.....	5
frame... 1, 2, 3, 4, 5, 6, 7, 8, 9, 11, 20, 21,		light transmitting panels.....	62
22, 23, 24, 26, 27, 29, 30, 34, 36, 37, 51,		lite.....	6
52, 57, 58, 66		lite frame area.....	58
frame area.....	2, 27, 35, 52	lite frame area.....	2
frame U-Factor.....	9	lite frame U-Factor.....	58
garage door.....	2, 9, 55, 56, 57, 58	lite frame U-Factor.....	9
gas fill percentages.....	24	lite glazing frame.....	2
gas-fill.....	1	lock jamb.....	37
glass.....	5	long-term energy performance.....	1
glass block.....	1	model size.....	6
glazed envelope system.....	7	model size matrix.....	10, 24
glazing component test procedure . 25, 26,		mullion.....	6
51		mullion stiffener.....	6
glazing dividers.....	1, 2	mullions.....	26, 51
glazing grilles.....	1	muntin.....	4
glazing layers.....	1, 24, 62	muntin bars.....	1
glazing materials.....	1	muntins.....	5
glazing system.....	5	NFRC 100.....	21, 25
glazing/glazing in-fill.....	5	NFRC 100-2001.....	ii
greenhouse/garden window.....	6	NFRC 101.....	20
grid.....	4	NFRC 102.....	21, 64
grille.....	4	NFRC 200.....	ii
grouping.....	6	NFRC 400.....	ii
hardware.....	56	NFRC 500.....	ii
head jamb.....	37	NFRC Simulation Manual.....	19
header.....	2	Reference 2.....	19, 36, 49
hinge jamb.....	5, 37	NFRC-approved software tools.....	66
hinges.....	37	no center-of-glazing area.....	22
honeycombs.....	4	Non-continuous element.....	24
horizontal sliding window.....	6	non-removable dividers.....	2
individual product.....	6	non-wood doors.....	36
individual products 6, 9, 24, 36, 37, 50,		OAVA.....	6
53, 66		obscure glass.....	6
inspection agency.....	66	opaque doors.....	36
IA.....	66, 67	opaque in-fill panel.....	5
insulative glazing panels.....	1	opaque in-fill systems.....	6
integral mullion.....	4, 6	opaque spandrel panels.....	62
ISO 15099.....	19, 20, 21	outdoor air ventilator assembly.....	6
Section 4.1.3.....	20	out-swing.....	35
Section 6.7.1.....	20	paint.....	4, 36, 56

panel area	58	Skylight.....	19, 50
panel area	2, 57	slab door.....	5
panel areas.....	2, 5	slab sidelite.....	36
p anel insert.....	4	sliding.....	34
panel U-Factor	9, 58	sliding glass door	7
panels	2, 4, 5, 7, 9, 36, 39, 40, 56	sloped glazing ...	7, 19, 22, 23, 24, 50, 63, 64
plastic	1, 4, 5, 8, 36, 62	software.....	25
plastic films.....	1	spacer	1, 5, 22, 24, 26, 51, 62
polyurethanes	4	spacer systems.....	1
poured and debridged thermal barriers ..	24	stain	36, 56
Product Certification Program	66	stained glass	1
product line	6	steel	1, 4, 5, 36, 37, 47
Product line	34	steel frame add-on.....	37
product type	7	stile area	57
projected area	2	stiles	4, 5, 7, 39
projected fenestration product area ...	27, 35, 52	storefronts	7
Projected fenestration product area.....	3	strip window.....	9
radiation model	19	structural capacity	1
rails.....	4, 5, 7, 26, 39, 40, 51, 57	structurally glazed framing	7
rectangular fenestration products.....	25	styrenes	4
reinforced vinyl.....	1	sunroom/solarium	7
reinforcing mullion	6	surface emittance	36, 56
representative production line specimens	36	testing alternative.....	6
representative size.....	7	Testing Alternative.....	10
representative size matrix	9, 10	thermal break	8
residential vehicular access doors.....	9	thermal transmittance.....	1, 8, 63
roof window	7	thermally broken (TB) members.....	8
sash.....	2, 3, 4, 5, 6, 7, 8, 9, 11, 33	thermally broken aluminum.....	1
Sash kit.....	34	thermally improved (TI) members.....	8
Schematic	29	threshold.....	2, 5
sealing	22	tinted glass	1
shading systems	1	tints.....	1
sidelite.....	7	total door system U-Factor.....	58
sidelites	36	total fenestration product area.....	3
sight line.....	2, 7, 27	total fenestration product U-Factor	9
sill.....	5	transom.....	8
sill add-on.....	37	transoms	8, 36
simulated divided lites	1	true divided lites.....	1
simulated dividers	2	true dividers	2
simulation laboratory ...	11, 22, 24, 25, 34, 66	tubular daylighting device.....	8, 52, 53, 54
single hung windows.....	9	Tubular daylighting device	19
site-Built Products.....	7	tubular skylight	54
skylight.....	7, 49	U-factor divider.....	8
		U-Factor	8
		unitized construction.....	62

U-value.....	8	Vinyl caps	14
validation matrix	9	water tightness	1
validation testing.....	3, 7, 63	weatherstrip.....	5, 36, 42, 43, 44
varnish.....	36, 56	window wall.....	9
vehicular access (garage) door.....	9	window walls	7, 23
ventilators.....	9	wood.....	1, 4, 5, 36, 37, 47, 50
vertical sliding window.....	9	wood laminates	4
vinyl	1	wood veneers	4