

Topics

- Simple (specular)

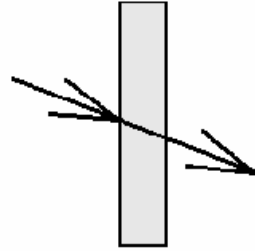

- IGDB

- Diffuse

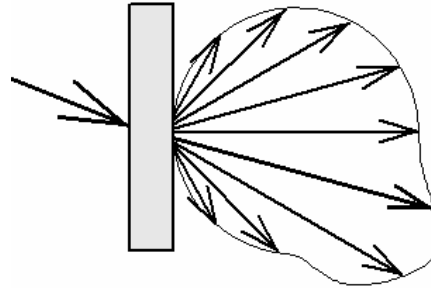

- CGDB

- Complex

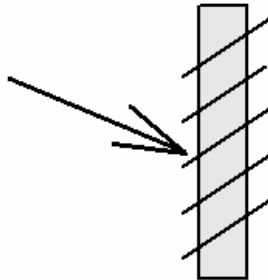

- CGDB

Detailed Topics

- Simple(Specular) Glazing
 - calculating data using Optics5 (or other programs) e.g. laminates with embedded coatings (LECs)
 - interlaboratory comparison update
 - implications for ASTM (NFRC) and ISO standards
- Diffuse Glazing (fritted, etched, sandblasted glass; diffuse interlayers etc.)
 - calculation of glazing units
 - measurement
 - standards
- Complex Systems
 - results on Venetian blinds
 - raytracing
 - priorities

Status of Optics5 Tools

- Change Thickness
- Switch Coating
- Apply Film
- Construct Laminate
- Construct Laminate with Embedded Coating

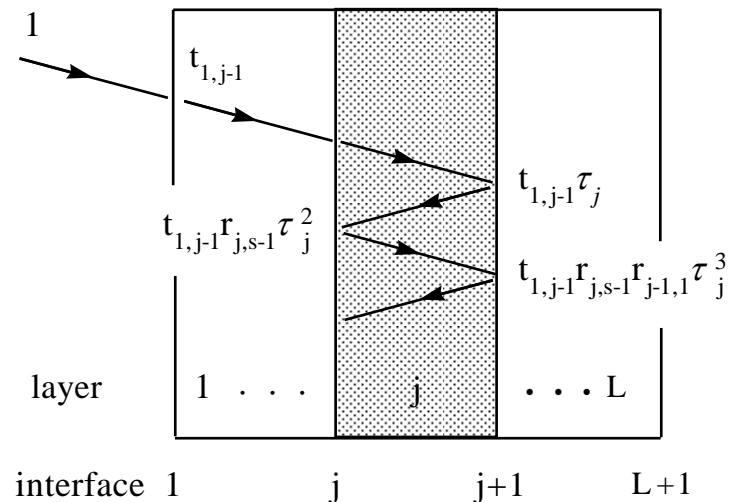
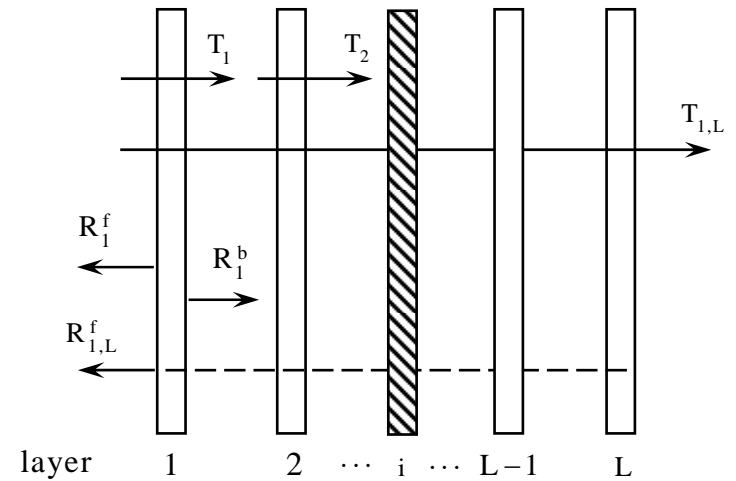

Change Thickness or Switch Coating

- Submit a self-consistent series
- Not approved or under discussion
- Same level of risk as construct laminate
- Approval “recommended”

Construct “Simple” Laminate

- Procedure approved
- Posted on LBNL website and also called NFRC 303
- Simulators only
- Resultant laminate does not enter IGDB

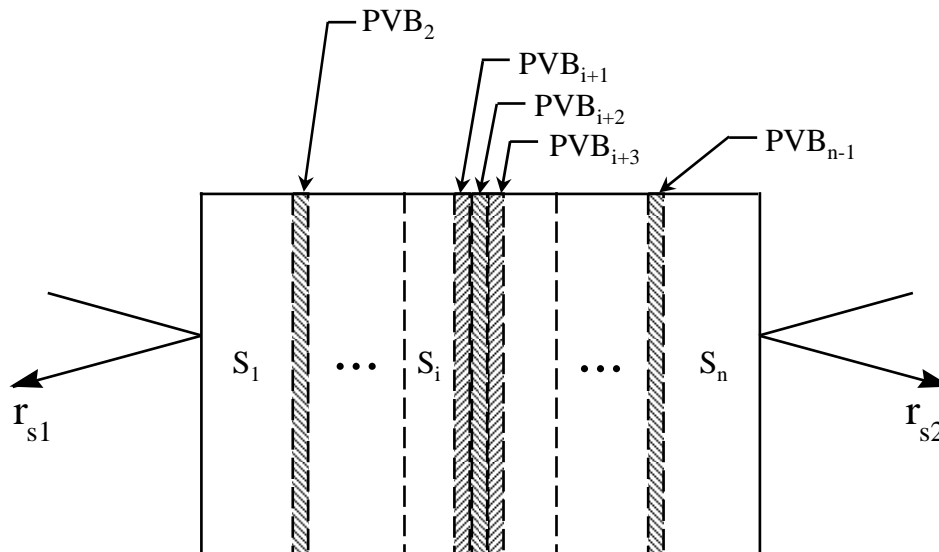

Apply Film

- Attachment product procedure approved - Document designation?
- Multiple configurations on label require 3 substrate types - 3mm clear, 6mm clear, 6mm grey
- Measure all three as usual and submit
- New procedure approved to calculate 2 using 1 measured – simulators only -Not yet implemented?
- Could also use to construct any laminate- not useful for NFRC unless window shipped with film

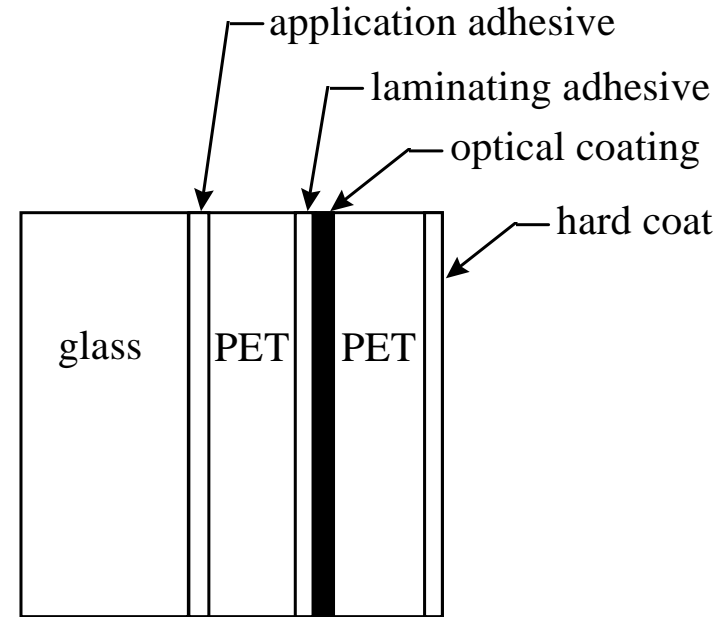

Laminates with Embedded Coatings

- Not yet approved
- Database checker program cannot add LECs at this time
- Some LECs were added by hand pre-checker
- Short-term solution: learn to add a few more by hand
- Long-term solution: fix the checker, change the process, validation, data control

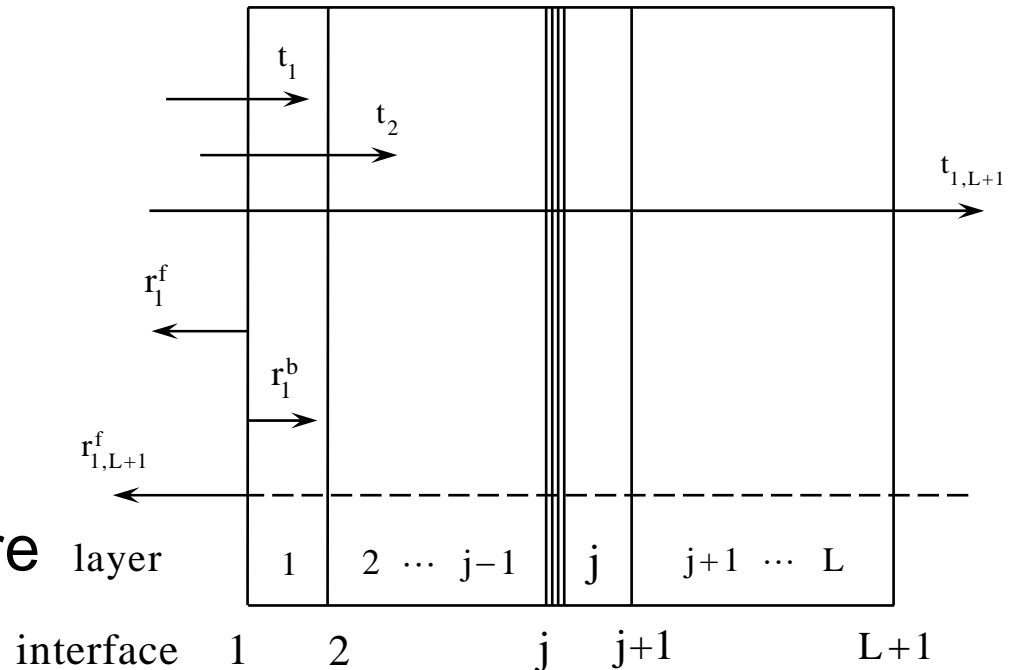

Calculation Summary

Tool	Optics5 Capable	Checker Capable	Approved
Change thickness	Yes	Yes	No
Switch coating	Yes	Yes	No
Apply Film	Yes	Yes	Yes
Simple Laminate	Yes	Yes	Yes
LEC	Yes	No	No

Interlaboratory Comparison

- 25 labs participating so far
- Solar and infrared (emittance)
- 1st round - one sample set in sequence
- 2nd round - many samples simultaneously
- Correlate instrument and procedure info with results
- Goals
 - Ensure all labs within acceptable limits
 - Guidelines for ASTM (ISO, CEN) Standards

Solar Spectra

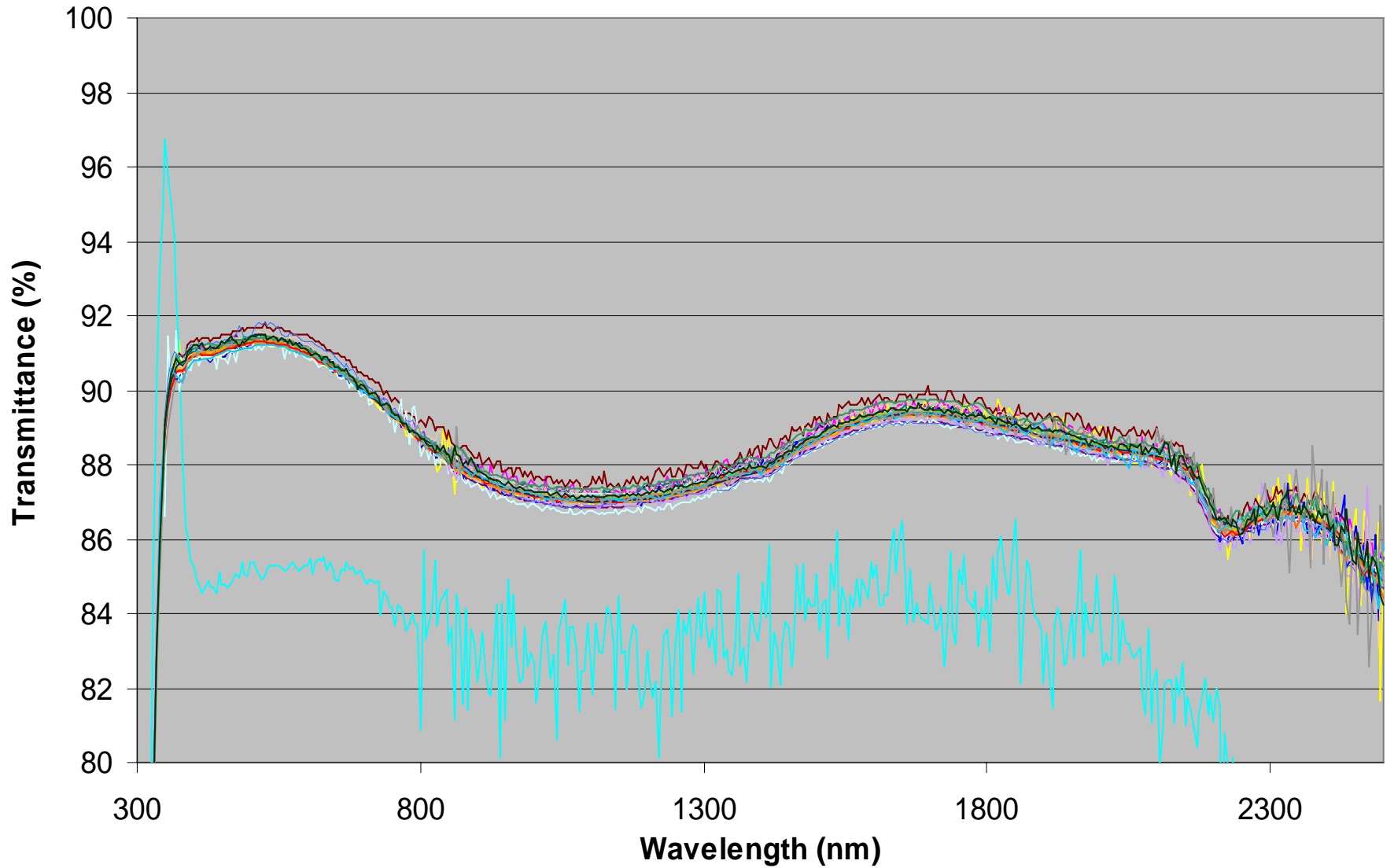

Visible Close-up

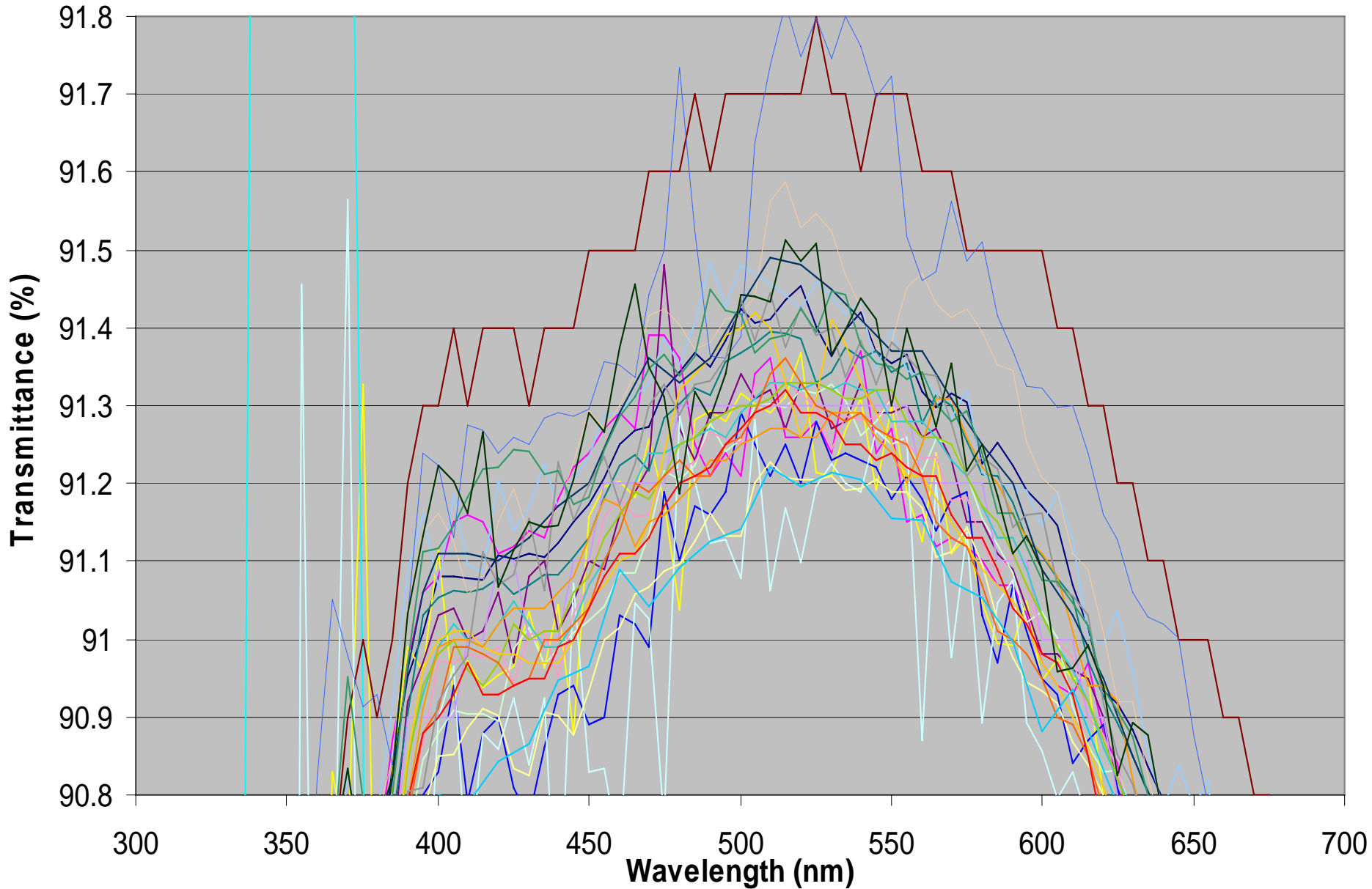

Noise

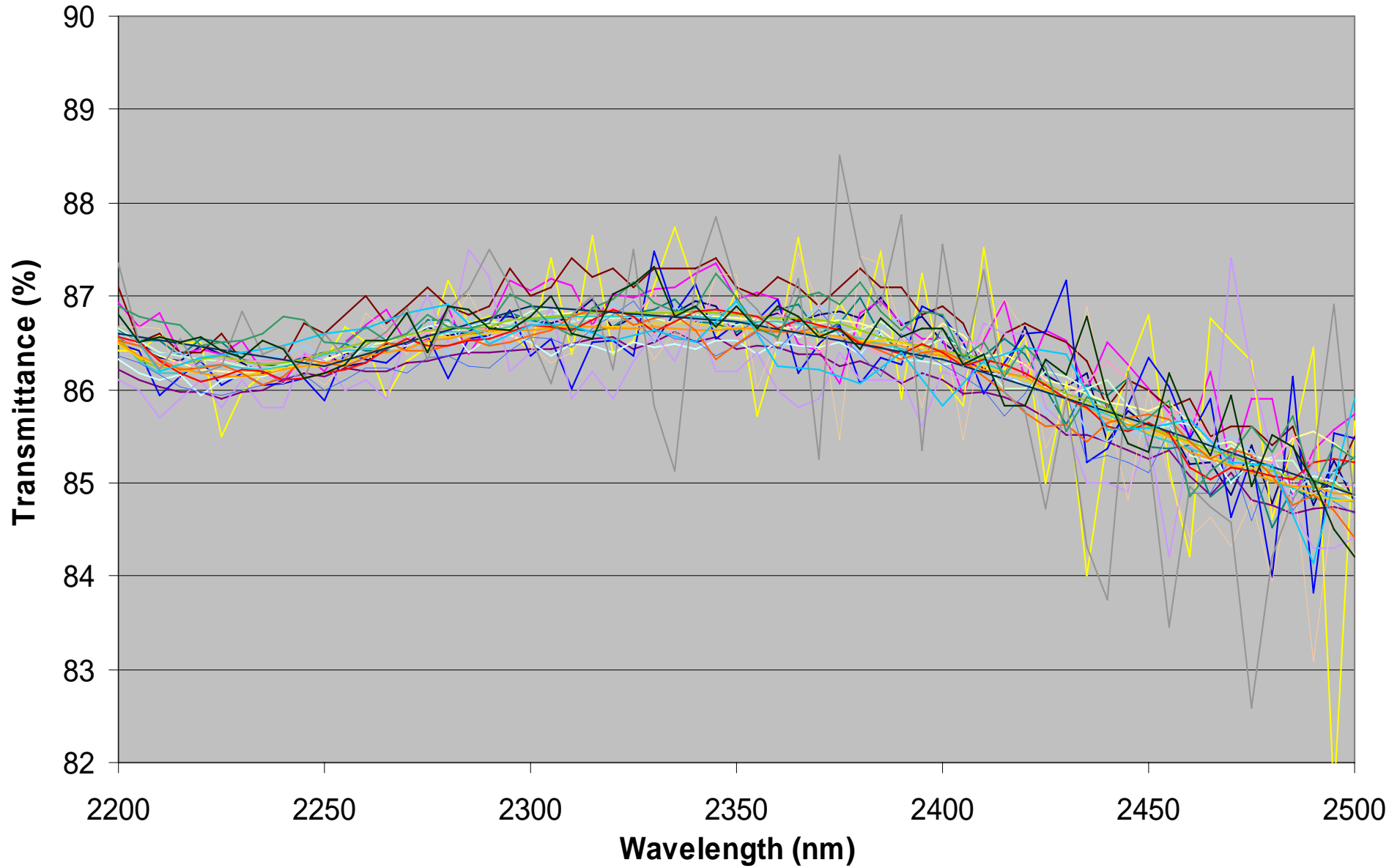

Planitherm Futur

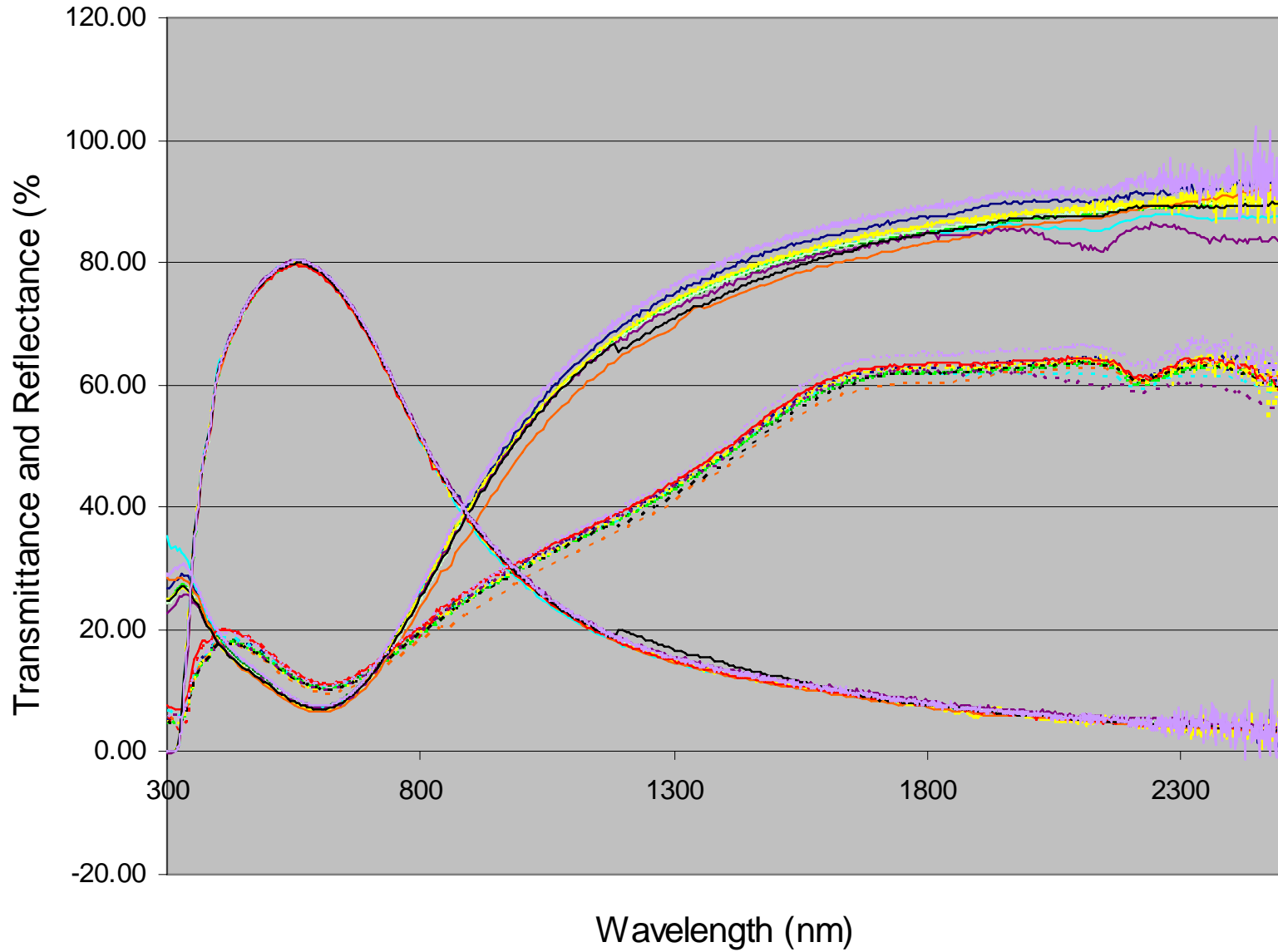

Sources of Error

- Transmittance

- Nonideal sphere
- Cleaning procedure
- Sample inhomogeneity
- No 0% calibration
- Scan parameters (noise)

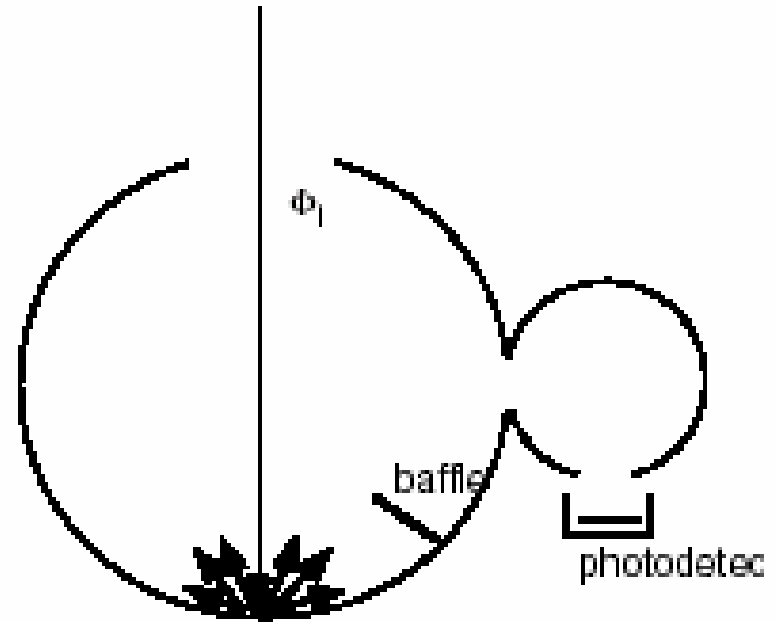

- Reflectance

- Bad standard reference mirror
- Improper correction
- Plus all problems of transmittance mode

ASTM E903- Solar T and R

- NFRC 300 – container for E903
- ASTM E903 – lapsed
- Reinstated E903 should be NFRC solar standard referenced only in NFRC 302
- Problems:
 - Measurement guidelines need much improvement
 - Does not include all spectral averages (take from 300)
 - Purports to include diffuse glazing
- Decision: patch and publish or major revisions for next document cycle
- Recommendation: patch now if needed by NFRC then harmonize with revised ISO 9050/ EN410 (and JIS...)

ASTM E1585 - Emittance

- NFRC 301
 - self-contained standard developed by PGMC
 - withdrawn in favor of E1585 clone
- ASTM E1585
 - Lapsed; back to 301
- FTIRs replace dispersive spectrometers
 - Disadvantages: stability lost, reduced spectral range
 - No more replacement parts for dispersives
- EU Thermes Project
 - ILC
 - Guidelines for proper use of FTIRs
 - “prenormative” research for CEN/ISO standard
- Recommendation: adopt or harmonize with Thermes/
ISO/ CEN

Emissometers

- Some results from sidebar to ILC
- Some results from old TG
- Fair correlation, good enough?
- New ILC with manufacturers and test labs? Thermophysical properties SC?
- Not consistent with international practice

Extending Standards and Ratings to Diffuse Glazing

- Multipane Calculation: built into Window6
- Measurement: “pullback” method, etc
- ICG TC 10 conducts ILC and prenormative research
- Rapid acquisition of data: New goniometer needed

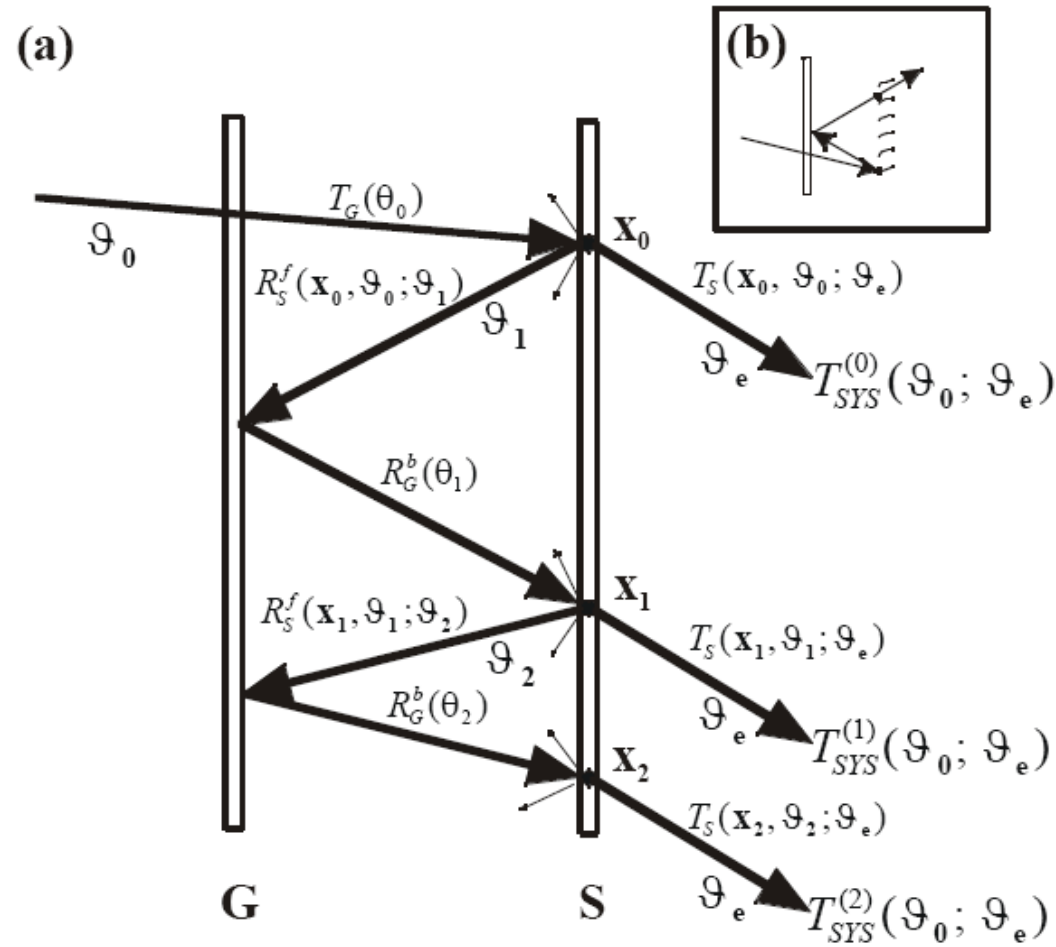

Measuring diffuse transmittance

- Sphere response depends on scattering distribution. Physical sphere \neq ideal sphere.

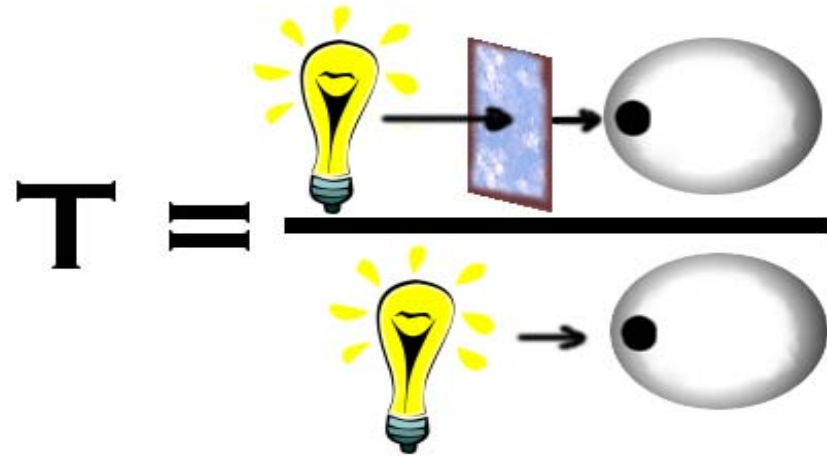

- Light transmitted through the sample does not enter the sphere

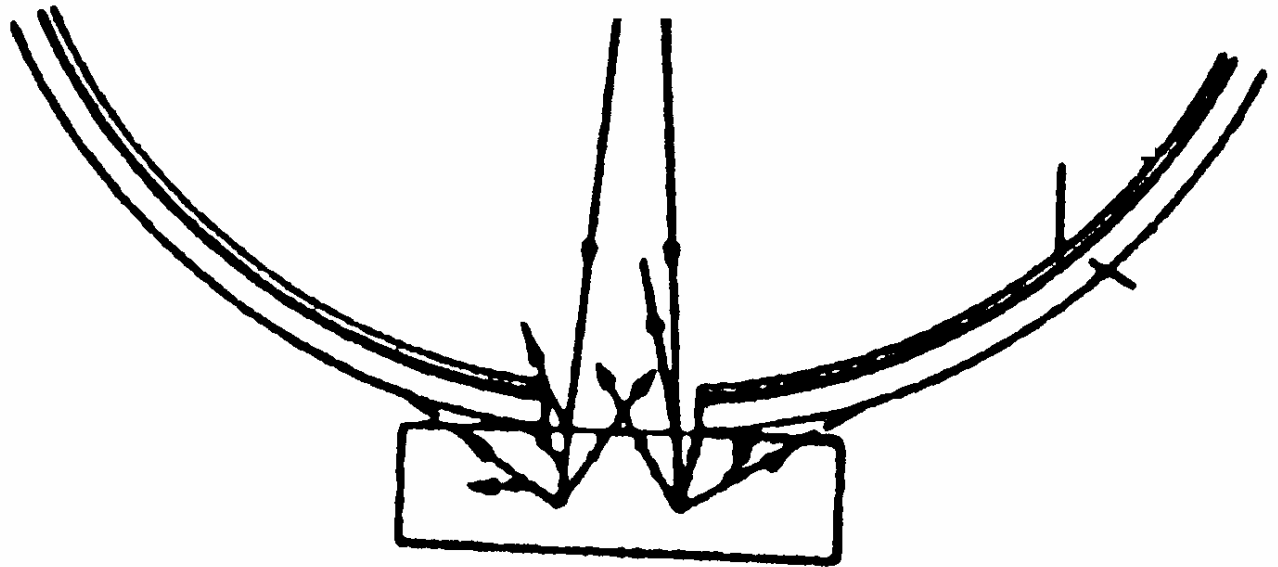

Measurement methods

- Large sphere: broad area illumination
- Small sphere: focus or mask beam
- Beam shift with fiber
- Port mount
- Center mount
- Variable distance “pullback”

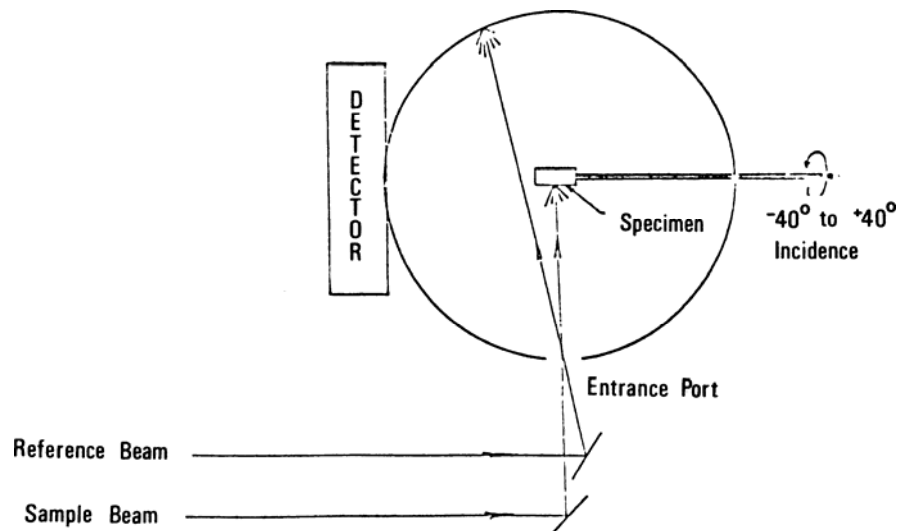

Large port, large sphere

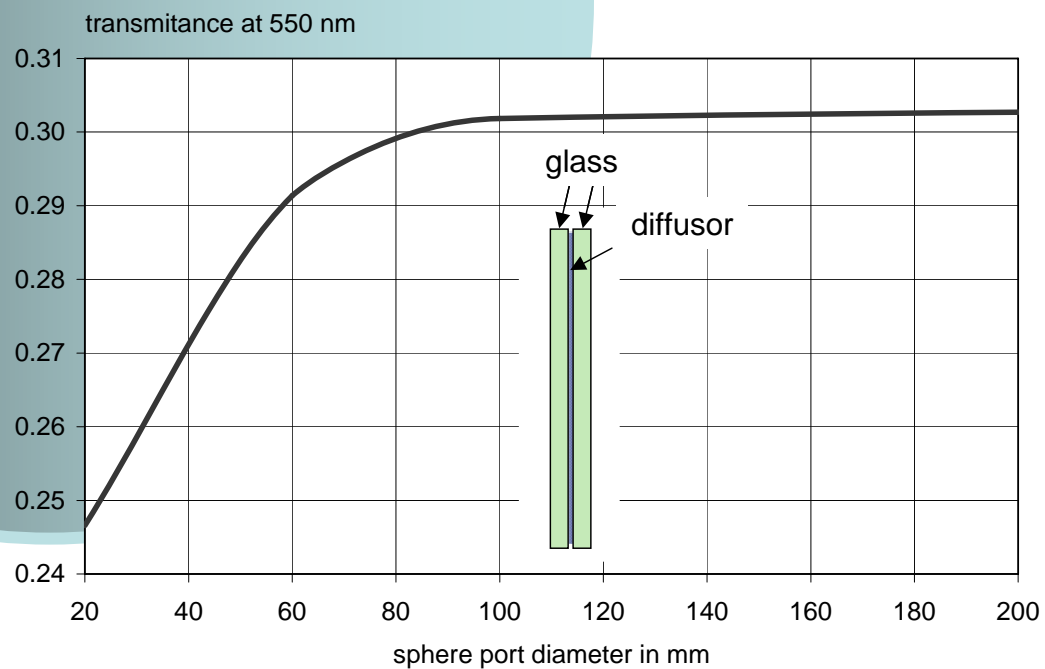
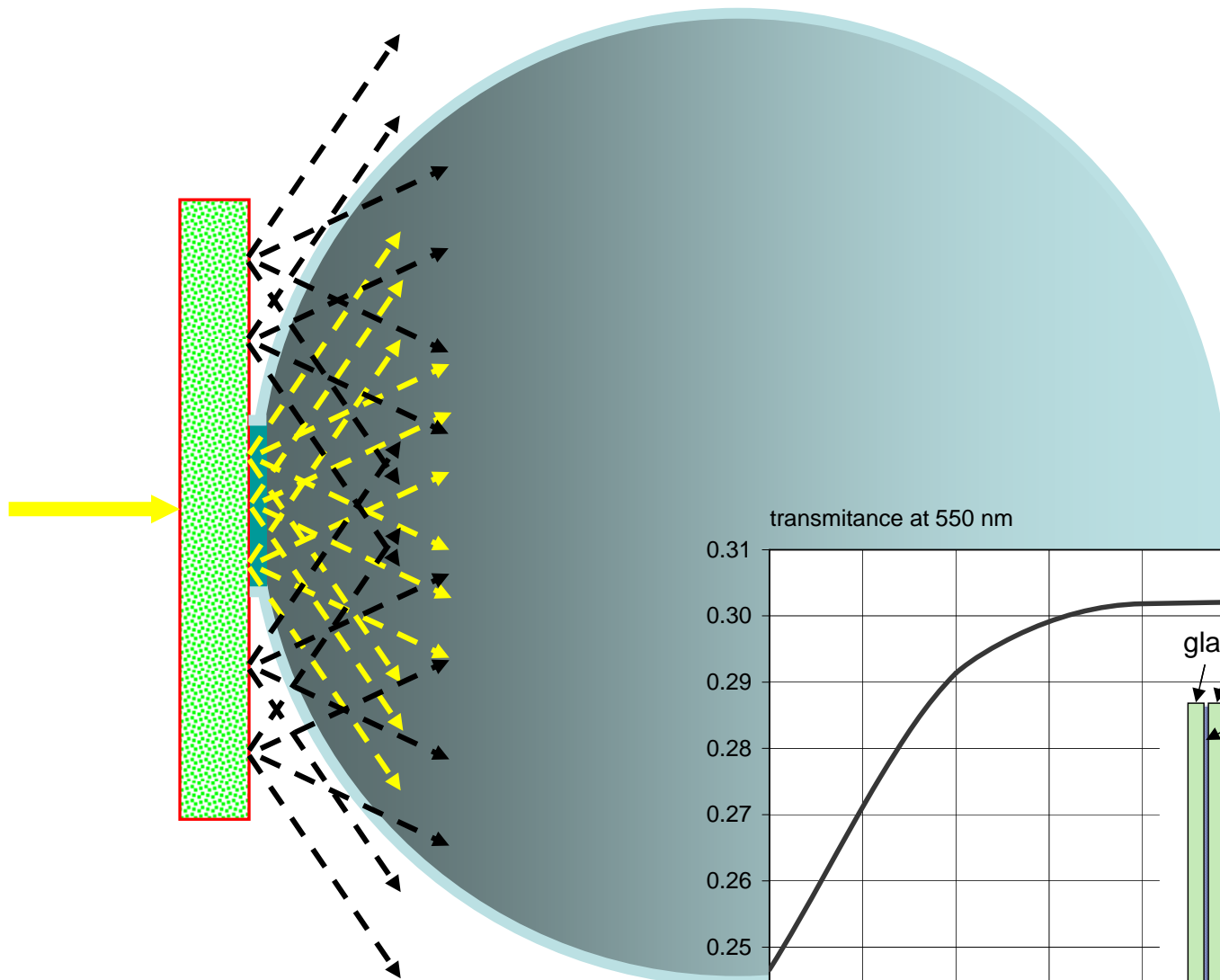

Beam-shift method

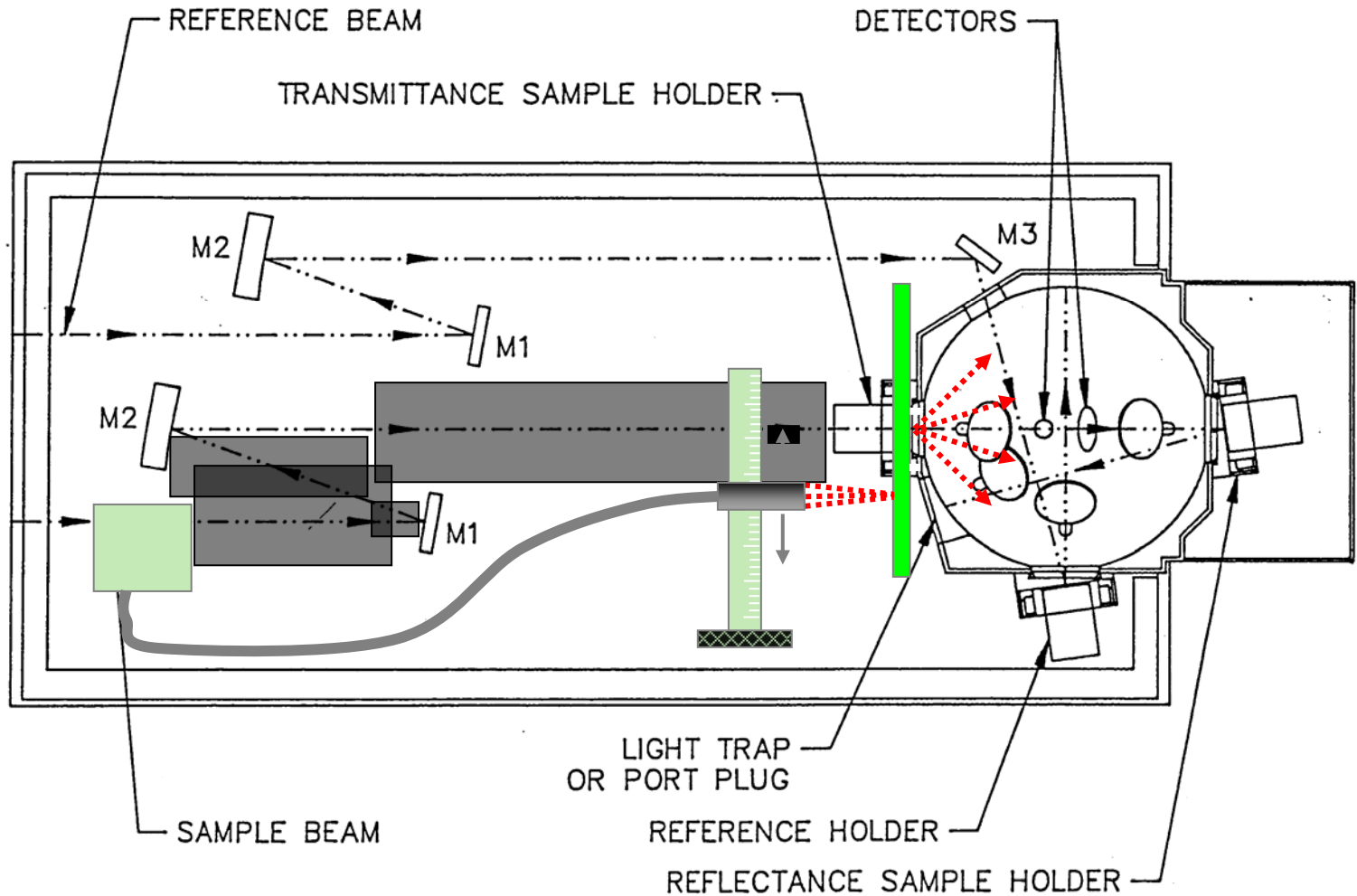

Summary of diffuse methods

Method	Transmittance	Reflectance	Variable Angle
Broad area	yes	no	no
Focused	yes	yes	no
Shift	yes	no	no
Center mount	no	yes	yes
Port mount	yes	yes	no
Variable distance+raytrace	yes	yes	yes

Variable-distance method applied to fritted glass

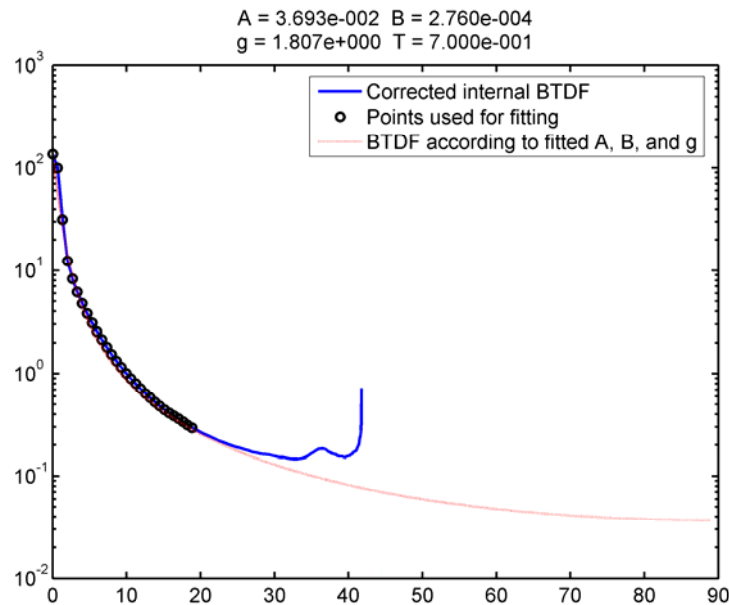
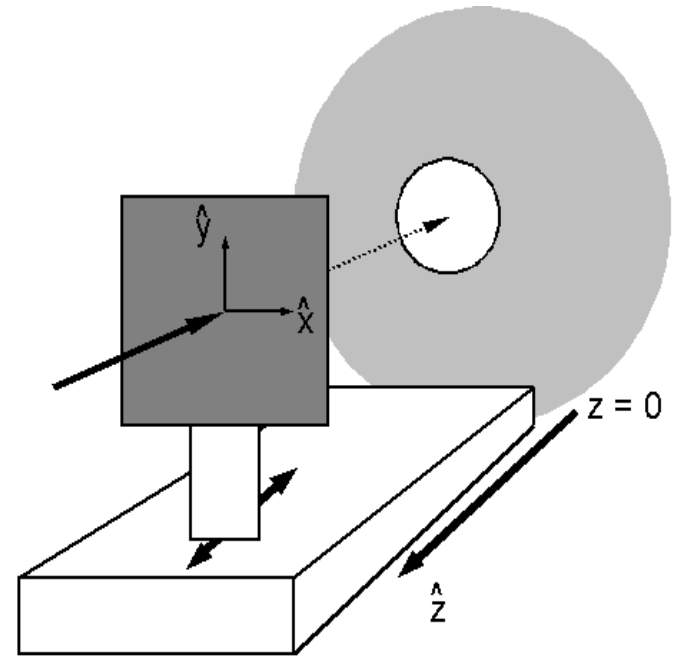
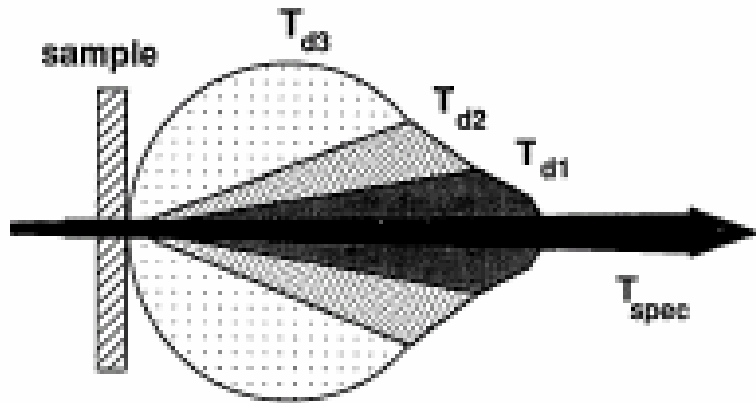

Comparing ray-tracing and experiment

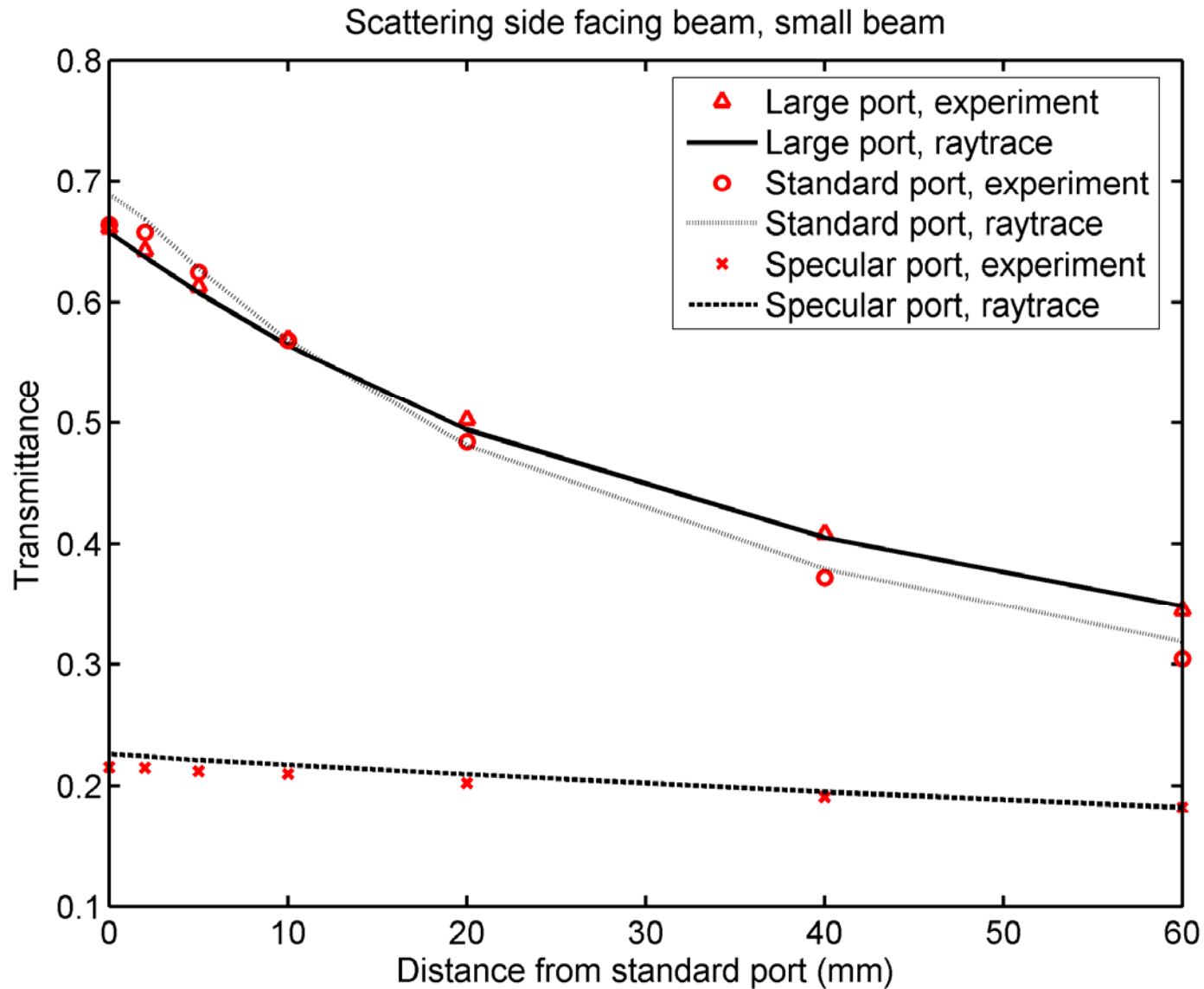

Venetian blinds: from raytracing to W6

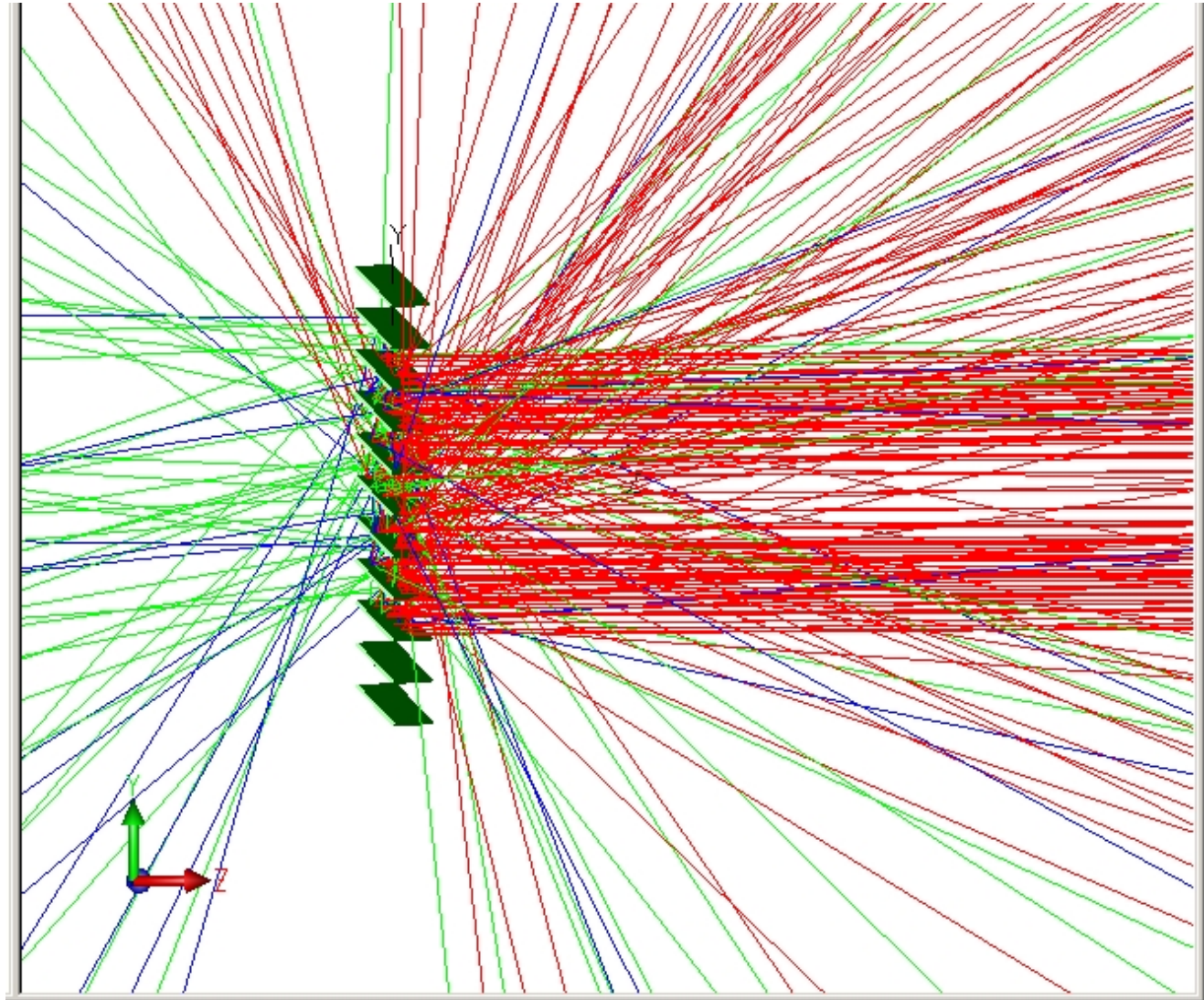

Virtual Goniospectroradiometer

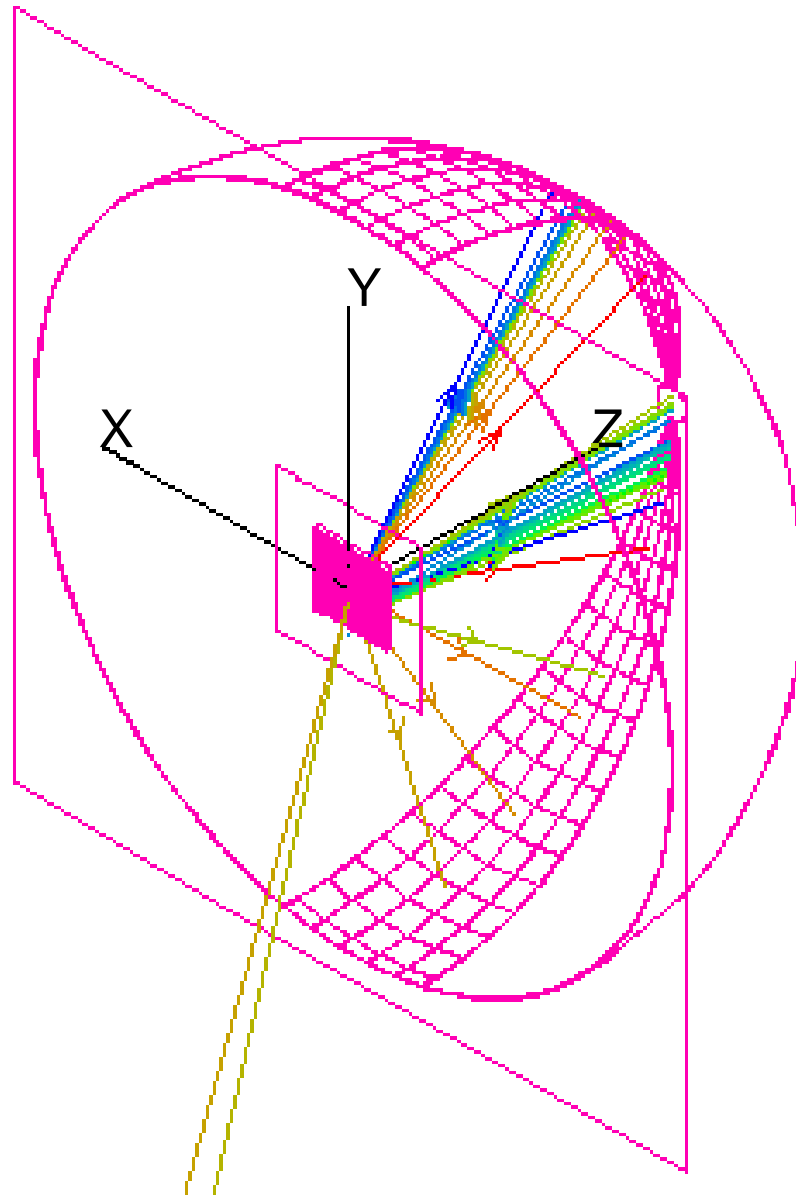

Full-Scale Measurement

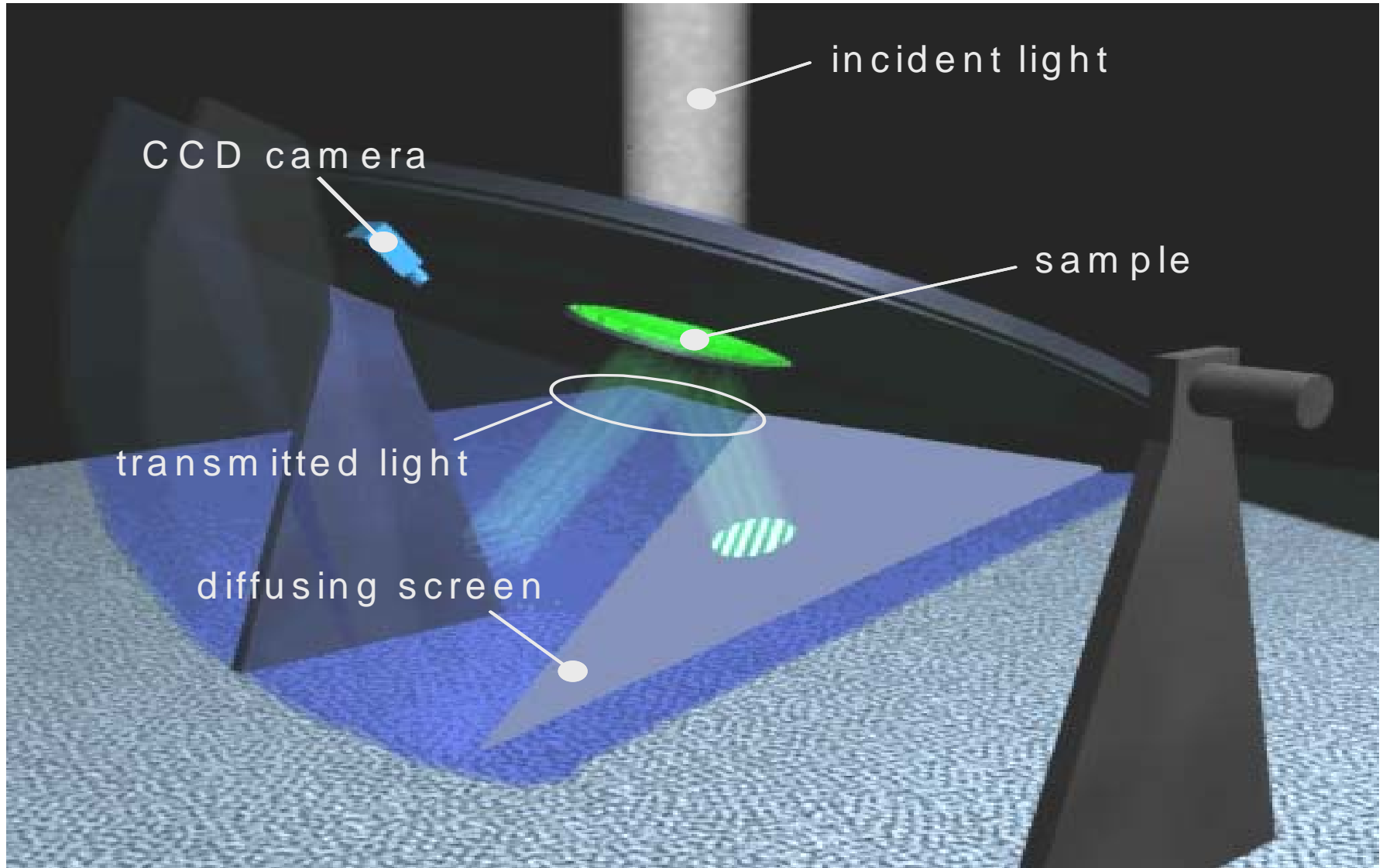

Slat Reflectance

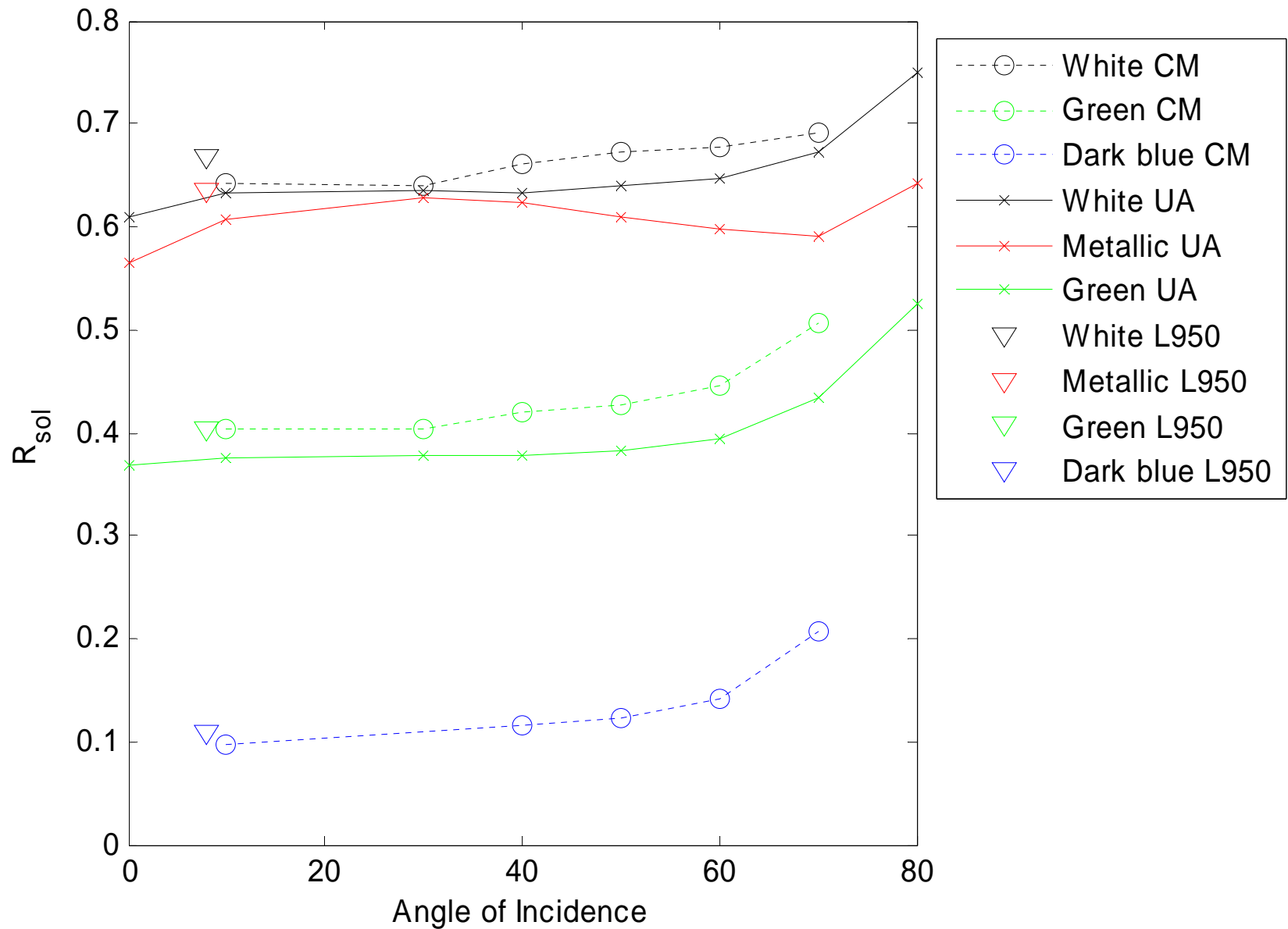

A45 blind transmittance

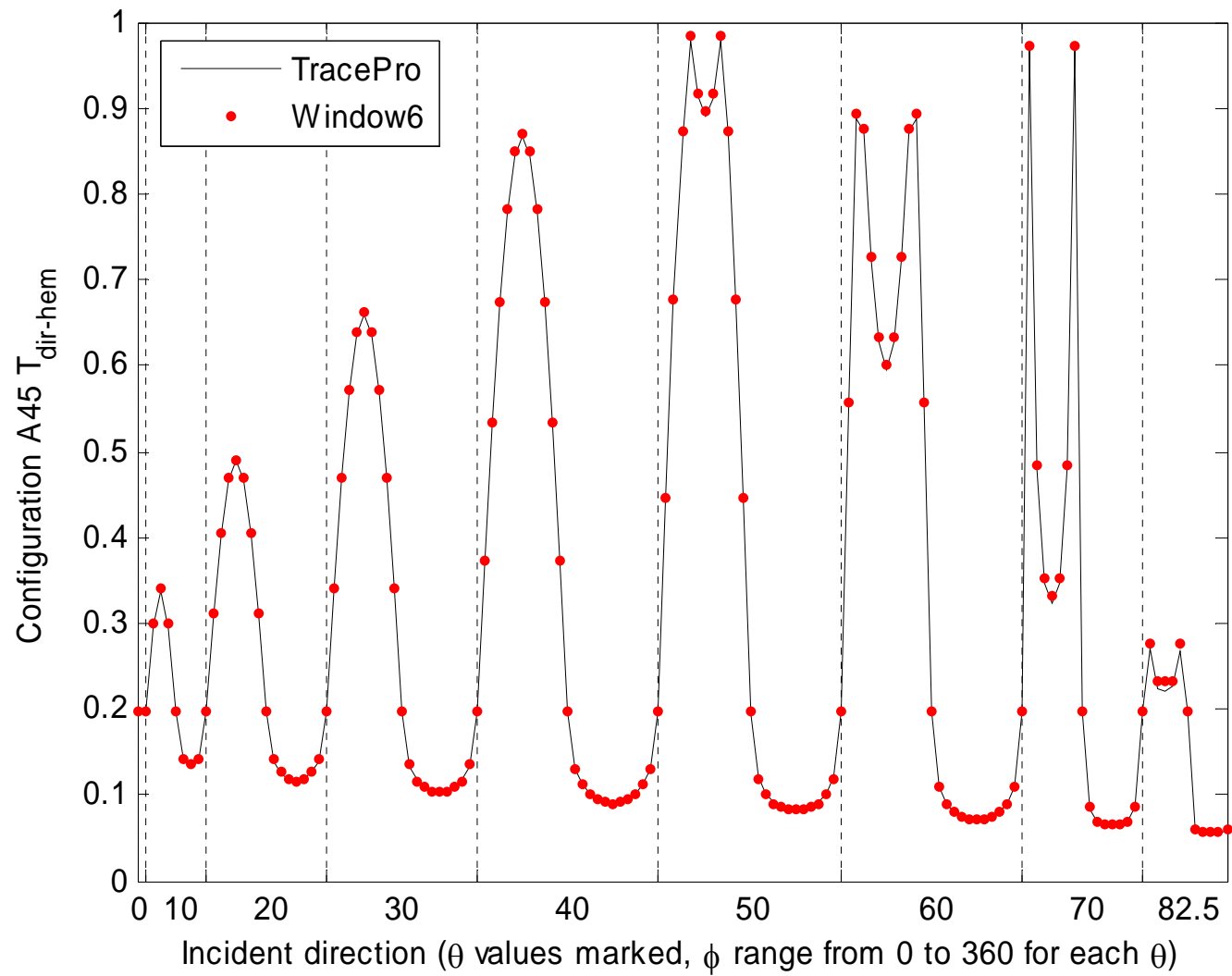

Effect of slat angle and reflectivity

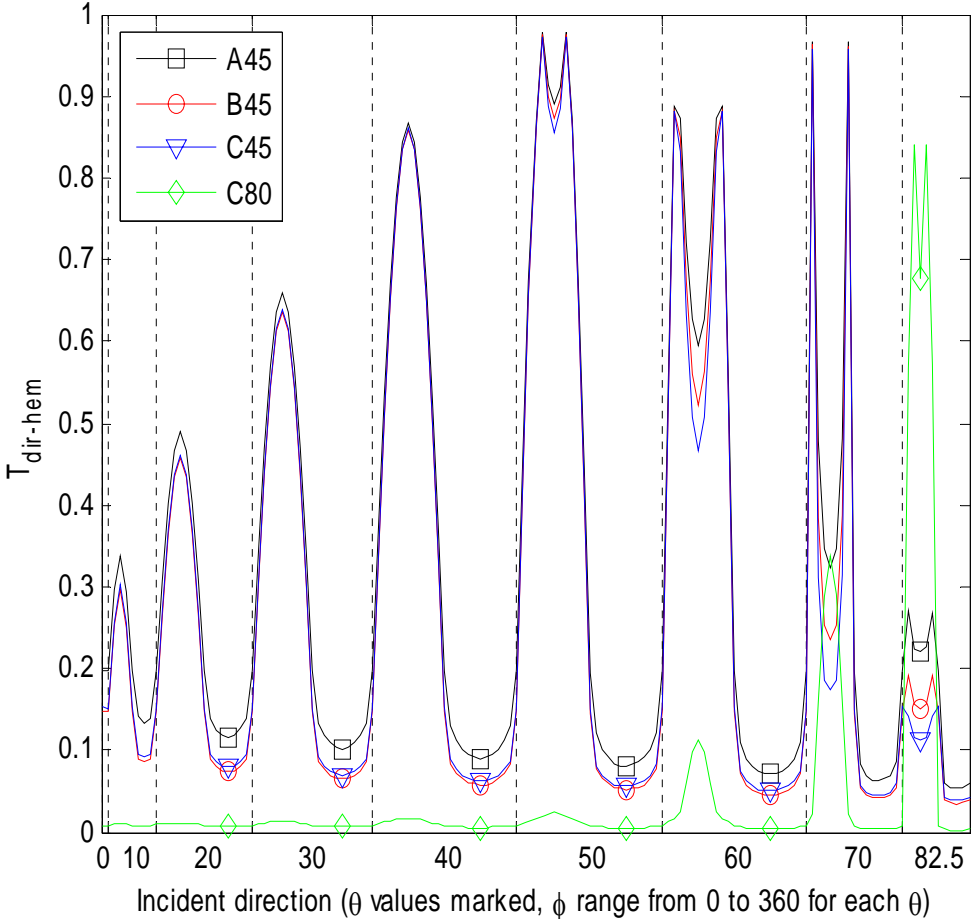

BTDF of A45 blind at normal incidence

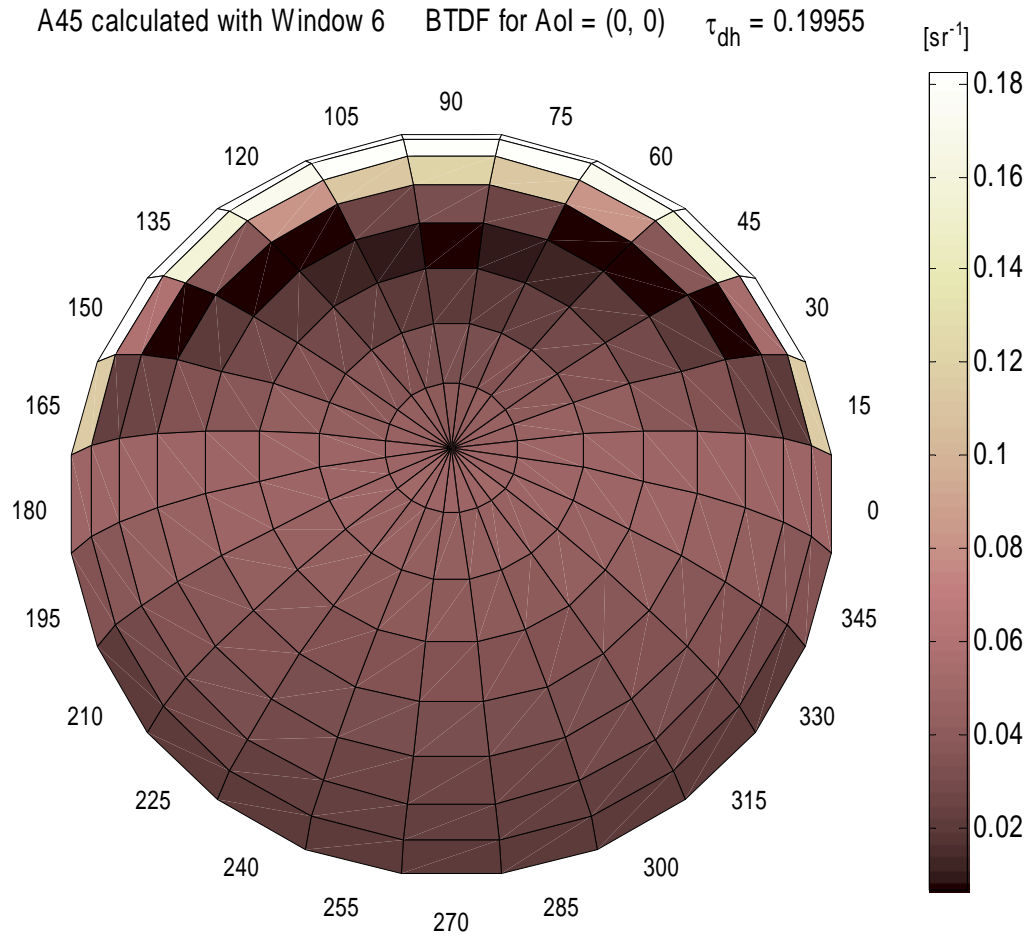

Difference between W6 and raytrace

Difference between Window 6 and TracePro Δ BTDF for Aol = (0, 0) $\Delta\tau_{dh} = 0.0017753$ [sr]

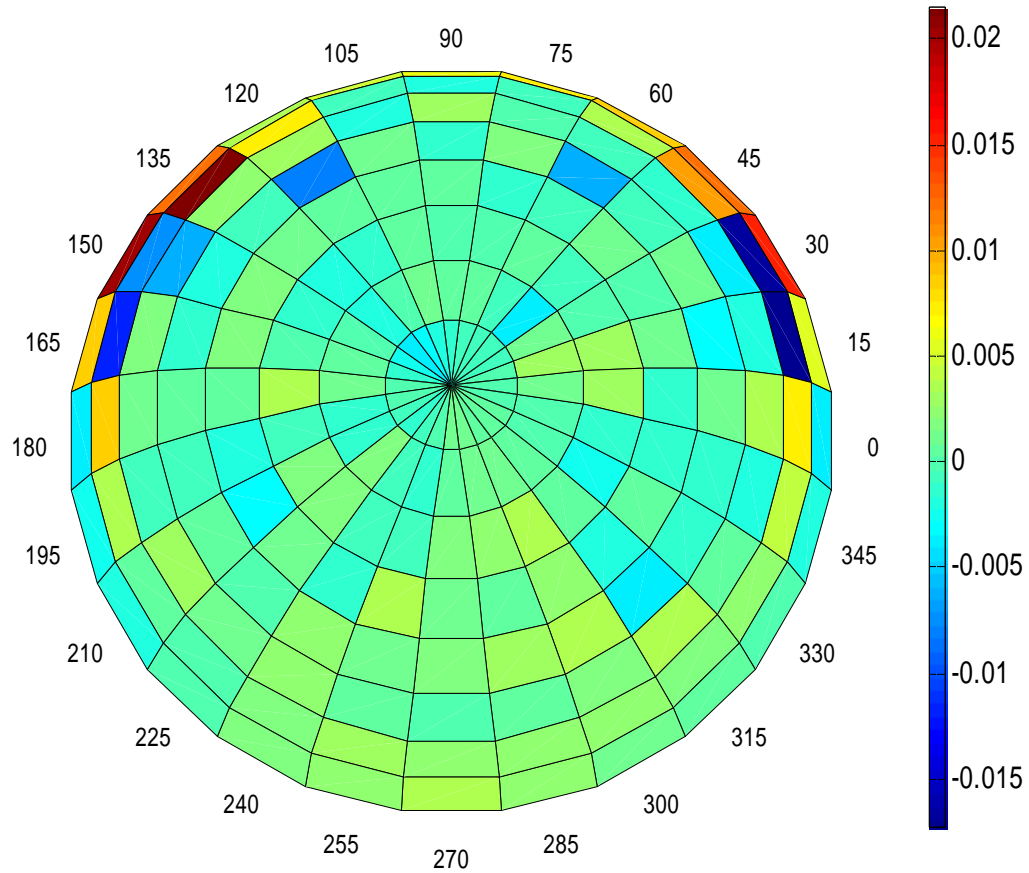

specular slats in W6

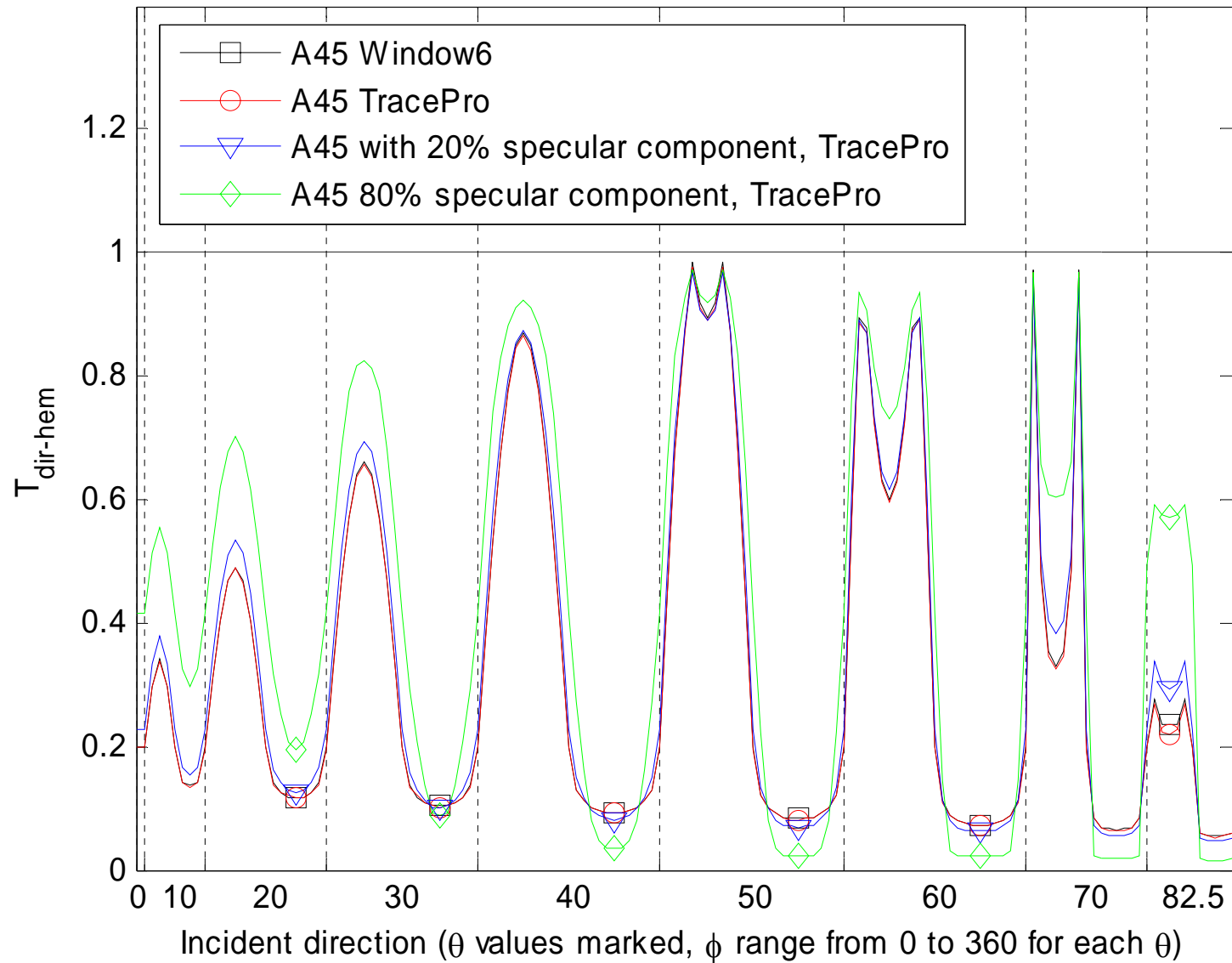

Raytracing: Conclusions

- Raytracing works and we are already using it
- Validation for each major system type
- Reduce to simpler models when possible
- Nonplanar TG: evaluate whether raytracing can be used by NFRC

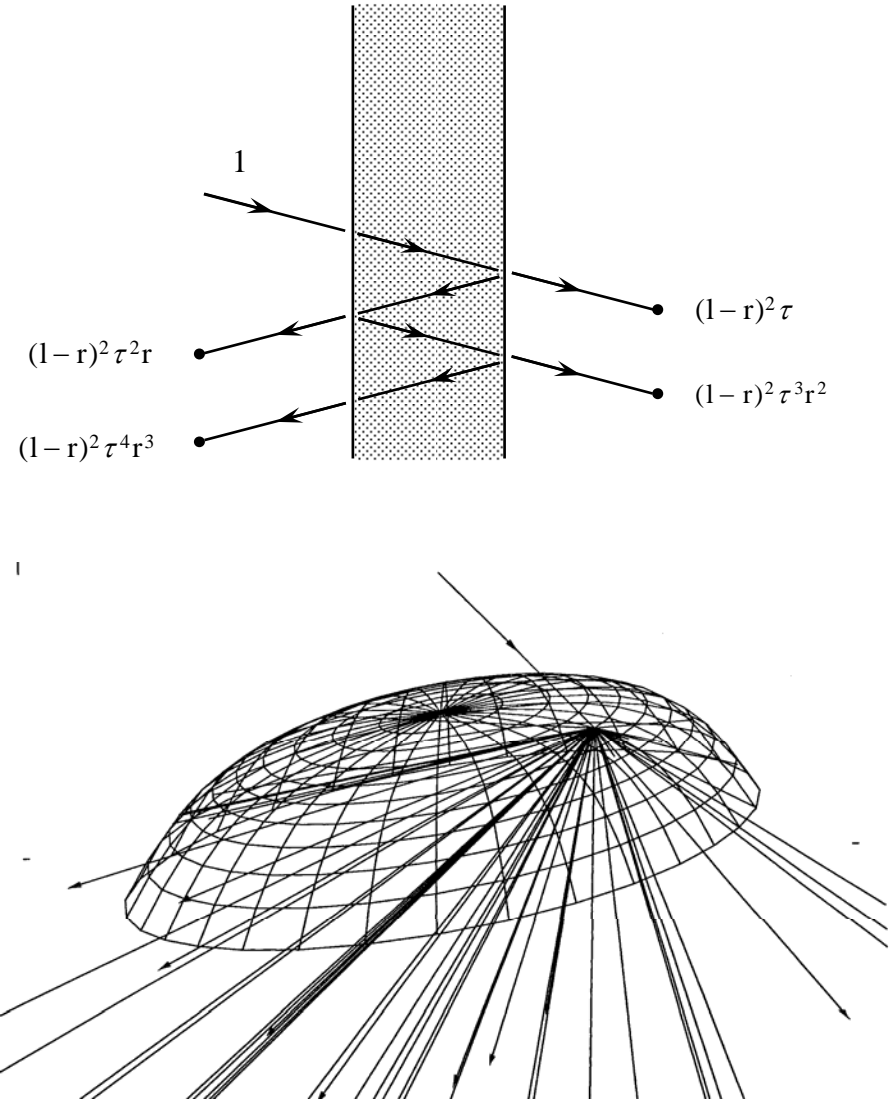

New Business: ASTM C14.11 WK 7854

- Committee Member, Jeff Haberer, Cardinal
- Transmitted color + Tv using colorimeter
- Tv tacked on
- No details; simply allows the use of certain instruments
- Correction factor for transmittance used by container industry:

$$T_{corr} = (1 - r)^2 T_{meas}$$